



**Roots &  
Branches™**  
Preserving The Tradition

---

# JOHNNY APPLE SAUCE MAKER

---

Model 250 Food Strainer

---

## Instruction Manual



## Table of Contents

Parts Diagram .....	3
Operating Precautions .....	4
Care Instructions .....	4
Product Overview .....	5
Preparing Specific Produce Types .....	6
Straining Tips .....	7
Assembly Instructions .....	8
Strainer Use Instructions.....	9
Helpful Hints .....	10
Chart for Screen/Spiral Combinations.....	10
Troubleshooting Guide .....	11
Food Strainer Motor .....	12
Motor Features .....	12
Important Safety Instructions .....	13
Grounding Instructions .....	14
Circuit Breaker Instructions .....	15
Motor Use Instructions.....	16
Removal Steps:.....	18
Motor Troubleshooting Guide.....	19
Product Warranty .....	20

\*For the most up-to-date manual, or for more information regarding this product, visit our website: **VKPbrands.com**

# JOHNNY APPLE SAUCE MAKER

## Model VKP250

### ATTENTION

Before using your new Johnny Apple Sauce Maker, please read and follow all instructions. Carefully study the diagrams on the following pages to become familiar with the various parts of your Food Strainer.

### Parts Diagram

Your strainer should come with all the parts shown and listed below:

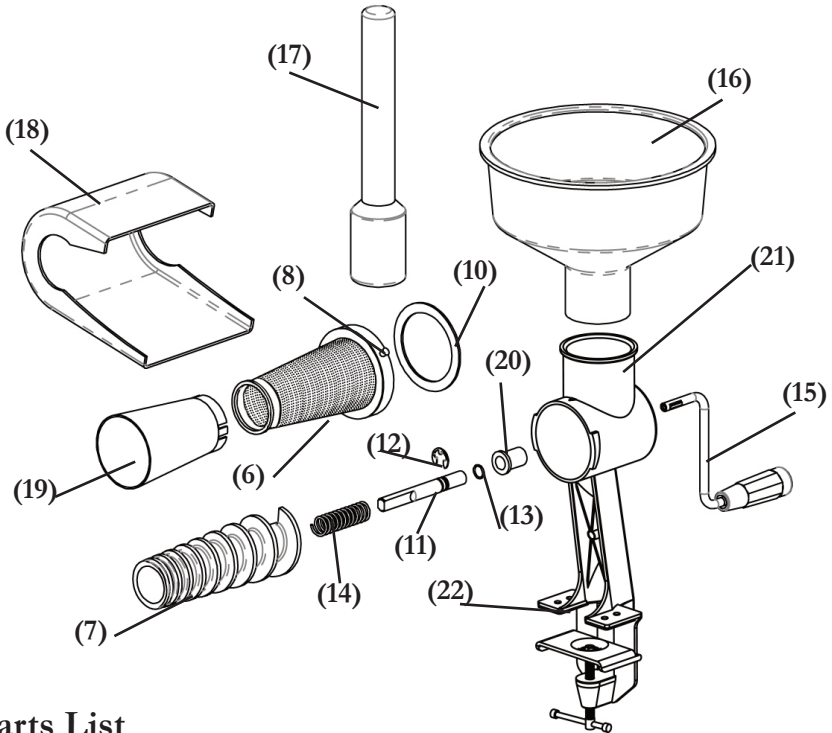

### Parts List

- |                                 |                             |
|---------------------------------|-----------------------------|
| 6: VKP250-6 Tomato/Apple Screen | 15: VKP250-15 Handle        |
| 7: VKP250-7 Standard Spiral     | 16: VKP250-16 Hopper        |
| 8: VKP250-8 Screen Screw        | 17: VKP250-17 Food Pusher   |
| 10: VKP250-10 Screen Gasket     | 18: VKP250-18 Squirt Guard  |
| 11: VKP250-11 Shaft             | 19: VKP250-19 Waste Spout   |
| 12: VKP250-12 Shaft Clip        | 20: VKP250-20 Nylon Bushing |
| 13: VKP250-13 Shaft Seal        | 21: VKP250-21 Body          |
| 14: VKP250-14 Spring            | 22: VKP250-22 Rubber Pad    |

**NOTE:** Parts 11,12,13 all come preassembled and inserted in 20 which is located in 21.

## Operating Precautions

- **WARNING! Never operate the strainer dry. This will damage the screen and spiral.**
- Never use any tool except the food pusher in the hopper.
- Keep hands, hair, clothing and any other objects, except the food pusher, away from the hopper opening, at all times.
- Never operate the food strainer if any parts are missing or damaged.
- Never operate the food strainer without clamping it securely in place.
- Never put hot foods into the food strainer. This could damage, crack or melt any plastic parts.
- Always make sure the food strainer is clamped securely to a sturdy surface before assembling and using. (See diagram below for correct mounting examples).

**Correct**

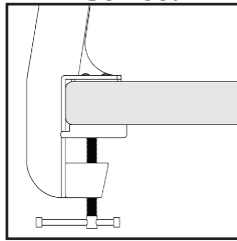

**Incorrect**

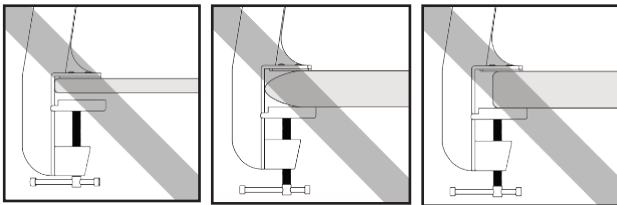

## Care Instructions

After using your Strainer, promptly disassemble and hand wash all parts in warm, soapy water. **Do not put the food strainer in a dishwasher.** This can cause discoloration of the body. Do not leave any of the parts soaking in water for a long period of time. Dry thoroughly after washing. When not in use, store the food strainer in the original carton away from direct sunlight, moisture and extreme temperatures.

**NOTE:** The plastic parts may become stained after straining cooked foods, such as tomatoes, berries, etc. This will not affect the operation of the Food Strainer.

## **Product Overview**

To give you an idea of the basic procedure, you will start by washing all parts of your strainer, assembling it correctly, preparing the produce you want to strain, filling the hopper halfway with the prepared produce and gently guiding it down into the strainer with the food pusher. The sauce, or pulp, will pour down the squirt guard and begin collecting in a bowl as you continue the straining process. The skins and seeds are easily separated and sent out the waste spout, away from your fresh, homemade sauce or puree. You can quickly make apple or tomato sauce, pumpkin pie filling, jams, jellies, and more.

In this manual you will find care instructions, how to prepare specific types of produce for straining, assembly instructions, instructions on how to use your food strainer, helpful hints and a troubleshooting guide.

Upon assembling your food strainer, you'll notice the spiral does not touch the back of the body. This allows the spiral to turn and move slightly back and forth with each crank. This motion presses the produce against the screen more effectively resulting in more juice/sauce and less waste. More importantly, it means gravity and the machine will be doing the heavy lifting, not you! No more need to cram the food into the machine with all your might. If you happen to have the optional Accessory Motor (VKP250-M), you can save your shoulders even more work!

## Preparing Specific Produce Types

While this sections teaches you how to prepare different types of fruits and vegetables, it also introduces optional accessory screens and spirals that do not come standard with the food strainer (see p. 10 for details).

### **APPLESAUCE**

It is best to use a variety of apple types. Make sure they are ripe and free of blemishes. Wash, and remove stems, then cut into quarters. It is not necessary to remove the skin, core or seeds. Use your Steam Juicer (sold separately) to steam the apples until tender – about 15 to 20 minutes. Drain and cool slightly. Process through the **Tomato/Apple Screen (Fine)** with the **Standard Spiral (Long)**. Season to taste.

### **TOMATO SAUCE AND SALSA**

For best results, use fresh, ripe, uncooked tomatoes. Wash and cut into quarters. Process through the Standard Screen with the Standard Spiral. To thicken the tomato sauce after straining, you can simmer the pulp in a pot on a stovetop to remove excess moisture. To turn your tomatoes into salsa use the **Salsa Screen (Extra Coarse)**. If using cooked or previously frozen tomatoes, use the optional **Grape Spiral (Short)**.

### **APRICOTS, PEACHES, PEARS, PRUNES, PLUMS, ETC.**

Wash the fruit and remove any pits. Do not put pits through the strainer. Simmer the fruit until soft. Drain and cool the fruit, then strain through the **Tomato/Apple Screen (Fine)** with the **Standard Spiral (Long)**. Season to taste.

### **BEANS AND PEAS**

Use any cooked beans or peas for soups, side dishes, bean dips, burritos, tacos, or enchiladas. Strain through the **Pumpkin Screen (Coarse)** and season to taste with onion, garlic, etc.

### **BERRIES**

Use the **Berry Screen (Extra Fine)** and **Grape Spiral (Short)** to process berries that have very small seeds. Wash the fruit, remove the stems, and process through the strainer. Perfect for making jams, jellies, pie fillings, dessert and ice cream toppings, and for dried fruit leather.

## PUMPKINS AND SQUASH

Use the **Pumpkin Screen (Coarse)** and **Standard Spiral (Long)** to process squash and pumpkin. Wash the outside of the pumpkin or squash thoroughly, remove seeds and cut into 1-2 inch cubes. Use your Steam Juicer (sold separately) to steam the pumpkin or squash until soft. Cool, then strain. Just right for pies, breads, and side dishes. Freeze in one-cup portions for later use.

## POTATOES

Make mashed potatoes quickly for large groups or families. No need to peel. Just quarter, cook until soft, and then strain through the **Pumpkin Screen (Coarse)** and **Standard Spiral (Long)**. Season to taste. (This is a staff favorite for holiday meals. No more peeling and ricing the potatoes as this method does that all in one!)

## GRAPES

Remove stems and rinse grapes thoroughly. Use the **Grape Spiral (Short)** when straining grapes to keep the strainer from binding or getting too difficult to turn. Strain the grapes using the **Tomato/Apple Screen (Fine)** for best results. Running the waste through a second time will yield more pulp and juice. If making jelly, not jam, consider using the Steam Juicer (sold separately).

## Straining Tips

- Use the **Grape Spiral (Short)** when foods have larger amounts of waste (seeds, skin, etc.) relative to the amount of juice or pulp. This will keep the food strainer from jamming as frequently.
- If you are getting undesirable amounts of seeds or peel in the finished product, switch to a finer screen.
- If waste contains excess amounts of juice or pulp, it can be processed through the food strainer a second time to extract the maximum amount of juice and pulp.
- The **Salsa Screen (Extra Coarse)** can be used on any food where an extra coarse texture is desired. Works best on foods that are seedless or when having seeds in the finished product is desired.
- Visit our website, [VKPbrands.com](http://VKPbrands.com), for more tips and videos on how to assemble and use your Food Strainer.

## Assembly Instructions

(Use with parts diagram on p. 3)

View our assembly video on our website at [VKPbrands.com](http://VKPbrands.com).

To begin assembly, mount the Food Strainer body (2) to a table or countertop. Do not overtighten (see diagram on p. 4).

- Put the spring (10) onto the shaft (9) which was preinstalled in the body for shipping.

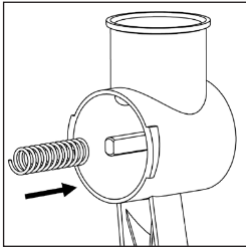

- Make sure the rubber gasket (12) is seated on the inside rim of the screen (14).

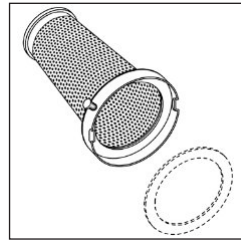

- Rub a small amount of food grade oil on the small end of the spiral (11) and put inside of the screen.

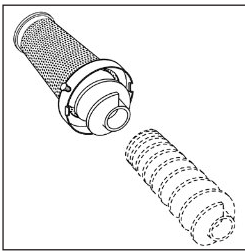

- Pull the spiral/screen assembly onto the body (2).

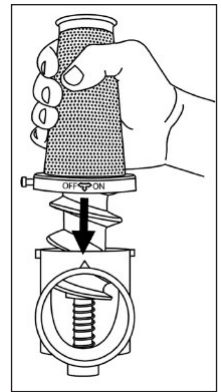

- Line up the arrow on the screen with the arrow on the body. Twist the screen towards the “ON” direction until the notches slide over the tabs on the body. Then, tighten the screen screw (13) to keep the screen in place.

Screen screw must be untwisted all the way, but should not be removed, before rotating the screen into place.

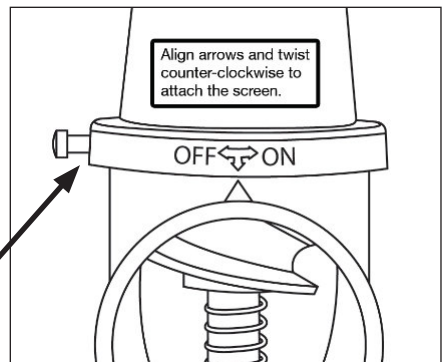



7. Snap the small end of the spout (15) into place on the end of the screen. Do not rock the spout side to side as it will damage the tabs.

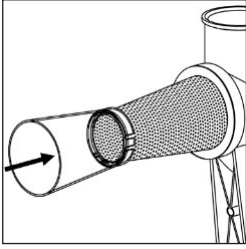

8. Slide the squirt guard (17) over the screen from the rear so it snaps onto the body and the small end of the spout.

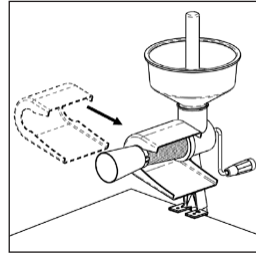

9. Place the hopper (1) on top of the strainer body (2) and insert the handle (5) in the end of the drive shaft. Your Food Strainer is now assembled and ready for use.

## Strainer Use Instructions

View our use video on our website at [VKPbrands.com](http://VKPbrands.com).

1. To prepare food for straining, wash fruits and vegetables thoroughly and cut into pieces small enough to fit into the opening at the base of the food hopper. Remove any pits and large stems. The Strainer will remove peelings, cores, seeds, and small stems. Detailed instructions for food preparation are found on p. 6.

2. Place two bowls beneath the strainer: one bowl under the screen to collect the sauce, pulp or juice, and the other bowl under the spout to collect the waste (see image at right).

3. Fill the food hopper half full. Use the food pusher to gently guide the food into the body as you turn the handle clockwise. **Do not force (cram) the produce into the strainer.** This can cause the spiral to jam and liquid to squirt out of the strainer. Allow gravity to feed the food into the body as much as possible.

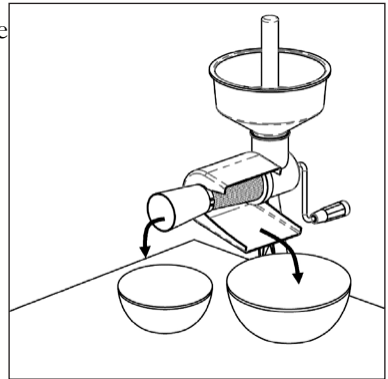





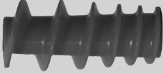

4. When processing has been completed, remove the squirt guard and use a spatula to scrape the remaining food pulp from the screen. Discard the waste peelings, cores, seeds, etc.
5. The strained food should be used immediately or preserved through canning, freezing, or dehydrating. To be assured of safety and quality in preserved foods, always use recipes from reliable home canning guides. For more information visit our website, [VKPbrands.com](http://VKPbrands.com).

# Helpful Hints

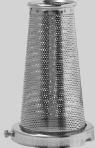
- The Food Strainer operates easily when fruits and vegetables are in the spiral, but difficult to turn when empty. Do not turn the handle when the Strainer is empty, as that will damage the screen and spiral.
- When straining certain foods, it is normal for some pulp to empty with the waste. The waste can be strained again to retrieve more pulp.
- The squirt guard may be removed, if necessary, when processing drier foods, such as beans or potatoes.
- If the Food Strainer handle becomes difficult to operate, turn the handle counter-clockwise a few complete rotations. This will help clear any obstructions and allow the Strainer to operate normally. If the handle is still hard to turn at this point, you will need to disassemble the Food Strainer and remove any obstructions in the screen and spiral.

# Chart for Screen/Spiral Combinations

 <p>*Grape Spiral (Short)</p>	 <p>Standard Spiral (Long)</p>	
<ul style="list-style-type: none"> <li>• All berries</li> <li>• Any soft/cooked food with small seeds and <u>low</u> juice content</li> </ul> <p><b>• Use Short Spiral if strainer jams with long spiral</b></p>	<ul style="list-style-type: none"> <li>• All berries</li> <li>• Any soft/cooked food with small seeds and <u>high</u> juice content</li> </ul>	 <p>*Berry Screen (Extra Fine)</p>
<ul style="list-style-type: none"> <li>• Tomatoes</li> <li>• Grapes</li> <li>• Persimmons (provided seed is smaller than narrowest part of the spiral)</li> <li>• Any soft/cooked food with a <u>low</u> amount of juice content</li> </ul>	<ul style="list-style-type: none"> <li>• Tomatoes</li> <li>• Cooked apples</li> <li>• Peaches (pits removed)</li> <li>• Plums (pits removed)</li> <li>• Apricots (pits removed)</li> <li>• Any soft/cooked food with small seeds and <u>high</u> juice content.</li> </ul>	 <p>Tomato/Apple Screen (Fine)</p>
<ul style="list-style-type: none"> <li>• Foods with very thick skins and/or large seeds to get a coarse texture</li> </ul>	<ul style="list-style-type: none"> <li>• Cooked pumpkin</li> <li>• Cooked potatoes</li> <li>• Cooked squash</li> <li>• Use to produce a coarse texture from any soft/ cooked food</li> </ul>	 <p>*Pumpkin Screen (Coarse)</p>
<ul style="list-style-type: none"> <li>• Foods with very thick skins and/or large seeds to get an extra coarse texture</li> </ul> <p><b>NOTE - Any screen &amp; spiral combination can be used. This chart is only a guide.</b></p>	<ul style="list-style-type: none"> <li>• Tomatoes</li> <li>• Chopped onions</li> <li>• Chopped peppers</li> <li>• Cooked apples for</li> <li>• Chunky applesauce (seeds and peels removed)</li> </ul>	 <p>*Salsa Screen (Extra Coarse)</p>

\*Grape Spiral, Berry Screen, Pumpkin Screen, and Salsa Screen Sold Separately

## TROUBLESHOOTING GUIDE

PROBLEM	SOLUTION
It is hard to turn the handle when the strainer is empty or dry.	DO NOT crank the handle while the food strainer is dry! Doing so will damage the screen and spiral. It is hard to turn because it is empty. Once food is placed in the hopper and you begin the straining process, the handle will be easier to turn.
It is very difficult to turn the handle when the strainer has food in it.	Rub some food grade oil (coconut oil, shortening, olive oil, etc.) on the small end of the spiral. This small amount of lubrication will help the spiral turn more easily.
The strainer has become stuck or jammed and is very hard to crank or cannot be cranked at all.	Crank the handle several times in reverse, then turn it forward again slowly. Do this a few times and if the jam is not cleared the strainer will need to be disassembled and cleaned out. If you are straining grapes, berries or produce with large seeds and thicker skins, see p. 10 for the Grape Spiral (Short) Accessory, under "Optional Screens and Spirals."
The seeds and skins coming out of the waste funnel are very wet and still contain juice or pulp.	Review the "Assembly Instructions," on p. 8, and be sure the strainer is properly assembled. Do not cram food into the body as overloading it will keep it from processing the produce efficiently, requiring it to be passed through the machine a second time.
The juice is backing up into the hopper and not going down through the screen	This will happen when the screen gets clogged with pulp or skins. High levels of sugar and pectin in some produce can cause the skins to stick inside the screen. Remove the squirt guard and scrape the pulp off the outside of the screen with a rubber scraper. The screen may need to be removed to scrape the skins from the inside.
The skins and seeds are getting into the sauce.	Review the "Assembly Instructions," on p. 8, and be sure the strainer is properly assembled. Small bits of skin or seeds may get through the holes in the screen when using a coarser screen. If this is a problem, try using a finer screen.

# FOOD STRAINER MOTOR

## VKP250-M (optional)

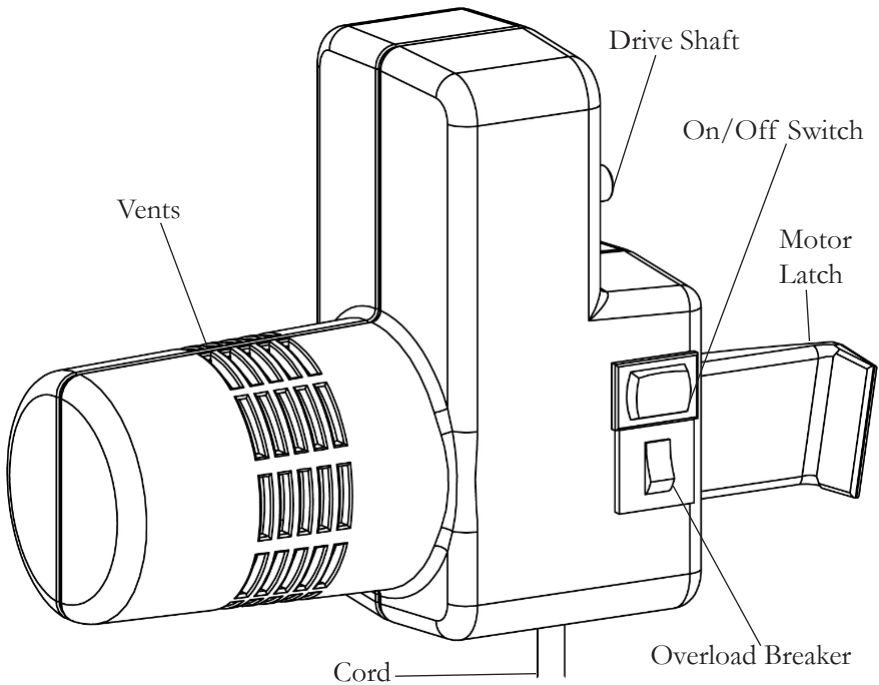

### Motor Features

- Installs quickly and easy to use.
- Energy efficient and durable.
- High torque power combined with all metal gears provide years of reliable service.
- Very low power consumption keeps your power bill low and allows for worry free use with backup emergency power such as generators or a battery powered electrical inverter.
- Motor specifications: 120 VAC, 60 Hz, 90 Watts.

# **IMPORTANT SAFETY INSTRUCTIONS**

## **WARNING!**

**Failure to follow these safety instructions correctly will lead to a risk of fire, electric shock or personal injury.**

## **SAVE THESE INSTRUCTIONS**

- When using electric appliances, basic precautions should always be followed, including the following:
- **Read and follow all instructions before operating the motor.**
- Connect motor to a properly grounded outlet only (See ‘Grounding Instructions’ on p. 14).
- Do not use electrical outlet adapters with this appliance.
- Do not operate if the cord or plug is damaged, or after the appliance malfunctions, or is dropped or damaged in any way. Return the appliance to the manufacturer for examination, repair, or electrical or mechanical adjustment.
- Do not disassemble. The motor must be serviced by qualified technicians only.
- To disconnect the motor, turn all controls to the off (“O”) position, then remove the plug from the outlet.
- Do not unplug by pulling on the cord. To unplug, grasp the plug, not the cord.
- Do not leave the motor plugged in when not in use and before servicing or cleaning.
- Keep the motor unplugged and make sure the switch is in the off (“O”) position when installing or uninstalling from, the food strainer.
- Never turn on the motor with nothing in the strainer.
- Do not use the motor for frozen foods or fruits with pits.
- To reduce the risk of electric shock, do not immerse the motor in water or other liquid. Do not place or store the motor where it can fall or be pulled into a tub or sink.
- Children should only use the Food Strainer under adult supervision.
- NEVER put hands or foreign objects in the strainer hopper, ONLY use the food pusher.
- Never use the strainer without the hopper in place.

- Do not cover the motor ventilation holes.
- Make sure the motor is attached to the food strainer properly before operating (See ‘Installation Instructions’ on p. 16).
- Only use electric motor (model VKP250-M) with Model 250 Food Strainer (model VKP250).
- This appliance is for household use only.

## **Grounding Instructions**

**(See diagrams below)**

THIS APPLIANCE MUST BE GROUNDED. In the event of malfunction or breakdown, grounding provides a path of least resistance for electric current to reduce the risk of electric shock. This appliance is equipped with a cord having an equipment-grounding conductor and a grounding plug. The plug must be plugged into an appropriate outlet that is properly installed and grounded in accordance with all local codes and ordinances.

**DANGER** – Improper connection of the equipment-grounding conductor can result in a risk of electric shock. The conductor with insulation having an outer surface that is green with or without yellow stripes is the equipment-grounding conductor. If repair or replacement of the cord or plug is necessary, do not connect the equipment-grounding conductor to a live terminal. Check with a qualified electrician or serviceman if the grounding instructions are not completely understood, or if in doubt as to whether the appliance is properly grounded. Do not modify the plug provided with the appliance – if it will not fit the outlet, have a proper outlet installed by a qualified electrician.

**Correct**

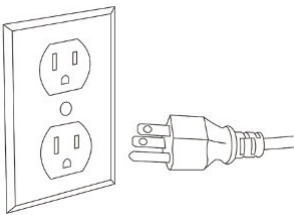

**Incorrect**

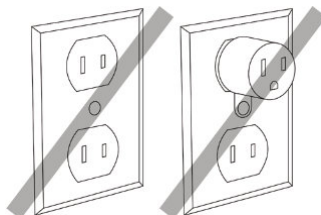

## Circuit Breaker Instructions

The motor includes a resettable overload breaker to prevent risk of personal injury or food strainer damage.

**Instructions for resetting overload breaker:** Turn the switch to the off (“O”) position and unplug the motor from the outlet. Remove the motor from the food strainer. Wait 10 minutes for the motor to cool, then manually reset the breaker by pressing in on the top of the breaker until it locks.

**Important:** Before reinstalling the motor, check the food strainer operation by installing the handle and manually operating the food strainer to make sure the spiral isn’t jammed or overly hard to turn. If the food strainer becomes jammed, please refer to Helpful Hint #4, on p. 10.

**Caution:** If the breaker trips immediately after plugging in or turning on the motor, do not bypass the breaker and do not use the motor. Contact customer service at 866-257-4741.

### Power Switch

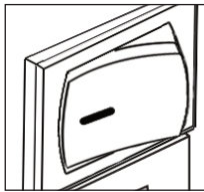

ON

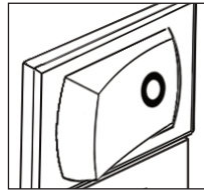

OFF

### Overload Breaker

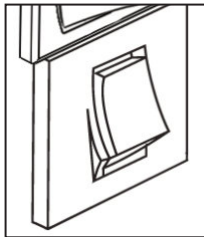

Breaker in normal operating position.

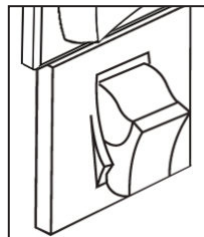

Breaker that has been tripped.

Motor specifications: 120Vac, 60Hz, 90Watts

## Motor Use Instructions

Make sure you have read the Important Safety Instructions on p. 13 before installing the motor.

### Installation Steps:

1. Remove the motor from the packaging and make sure the power switch is in the off (“O”) position (see diagram on p. 15) and the motor is unplugged.
2. Use the crank handle to position the strainer shaft so the motor shaft can fit in (see diagram below).

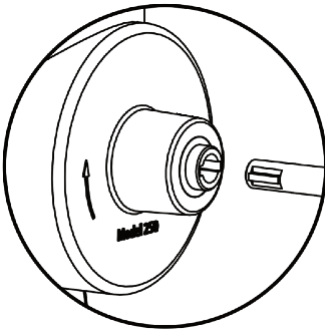

Strainer notches should line up with motor drive shaft keys.

3. Once the shaft is positioned correctly, insert the motor shaft into the food strainer shaft by pushing forward on the motor.
4. With the shafts connected, twist the motor counter-clockwise (see diagrams below).

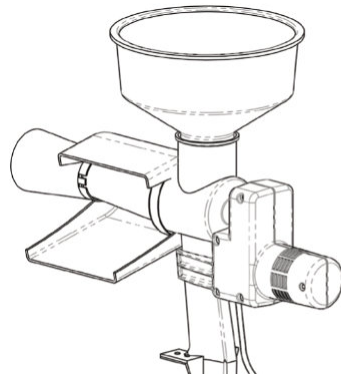
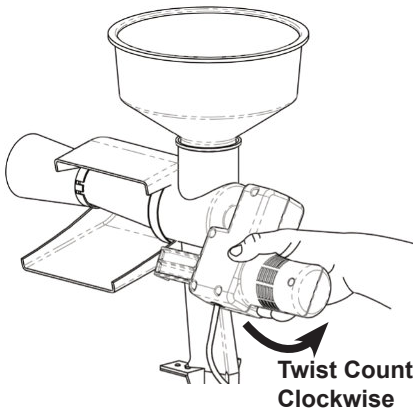



5. You will know the motor is correctly in place when the motor latch is secure around the strainer body (see diagram below) and the drive shaft is **FULLY** inserted in strainer.
  
6. Make sure the power switch is still in the off (“O”) position and plug the motor cord into a correct power source (see diagram on p. 14).
7. **WARNING! - Do not turn on the motor at this point! You will damage your strainer by running it when the screen and spiral are dry.**
8. Now that the motor is connected properly and plugged in, you can put your prepared produce (see p. 6 for specific fruit preparation instructions) into the hopper. If needed, review the Strainer Use Instructions on p. 9 before you begin the straining process.
9. You may now turn the power switch to the on (“I”) position. **Never use any tool except the food pusher in the hopper. Keep hands, hair, clothing and any other objects, except the pusher, away from the hopper opening at all times.**

## Removal Steps:

1. To remove the motor, make sure the power switch is in the off (“O”) position and the cord is no longer in the outlet.

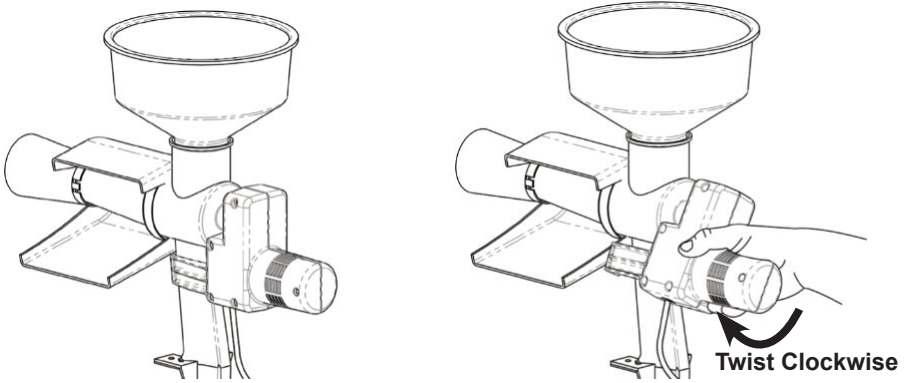

2. Firmly grasp the motor and twist in a clockwise direction to release the motor latch from the body of the strainer. (See diagram above).
3. The motor may be tight and hard to remove. If so, rock it up and down gently as you pull straight back. (See diagram below).

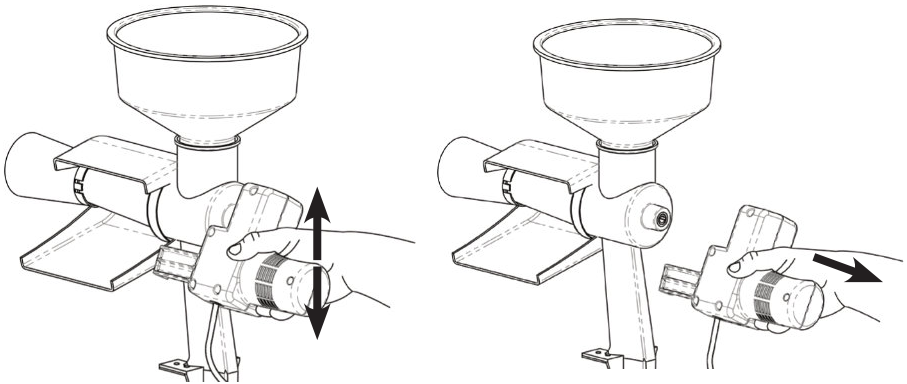

4. To store, place the motor back in its original box and packaging and keep it in a cool, dry place, away from moisture and extreme temperatures.

## MOTOR TROUBLESHOOTING GUIDE

PROBLEM	SOLUTION
I cannot attach the motor.	Review p. 16 on how to attach the motor, including how to correctly align the motor shaft with the food strainer shaft.
I cannot remove the motor.	Review the diagram on p. 18 and read how to remove the motor. Sometimes the motor shaft can get stuck or be difficult to remove.
The motor does not turn on.	Review the instructions and diagram on p. 15 about the Power Switch and the Overload Breaker.
The motor does not turn on and the overload switch is not tripped.	Make sure the cord is plugged into a live power outlet. Review the diagram on p. 15 about the Power Switch. Make sure the switch on motor matches the diagram on that page for the on, ("I") position.

## **Product Warranty**

Register your warranty online at:

**VKPbrands.com/Warranty**

Model VKP250 - Johnny Apple Sauce Maker Warranty: 5 years

Model VKP250-M - Optional Motor Warranty: 5 years

We are confident in the quality of our products and back each one with a limited warranty for the length of time specified above. Should you experience any problems with your product, please contact our Customer Service Department.

All warranty claims must be accompanied by a proof of purchase and are only valid if the appliance has been operated within the U.S. or Canada and used for its intended purposes. These products are for household use only.

### **Items Not Covered:**

- Return shipping costs or returned items lost in transit.
- Damages to the product due to accident, misuse, abuse, negligence, or if the appliance has been altered in any way.
- Products used outside of the United States or Canada.

# **VKP<sup>™</sup>**

**B R A N D S**

1804 Sandhill Rd

Orem UT, 84058

Phone: **866-257-4741**

**VKPbrands.com**

Roots & Branches is a trademark of VKP Brands  
© Copyright 2020 VKP Brands, all rights reserved