



---

*Deluxe*

# NUT ROASTER

---

Instruction Manual



## Table of Contents

Parts Diagram .....	3
Operating Precautions .....	4
Cleaning Instructions.....	4
Assembling Your Nut Roaster .....	5
Using Your Nut Roaster.....	6
Recipes .....	6
Spicy Maple Bacon Nuts .....	6
Honey Roasted Nut Brittle .....	7
Spiced Mixed Nuts .....	7
Product Warranty .....	8

\*For the most up-to-date manual, or for more information regarding this product, visit our website: **VKPbrands.com**

# Deluxe Nut Roaster

## Model VKP1225

### Parts Diagram

Your complete Nut Roaster includes everything shown below:

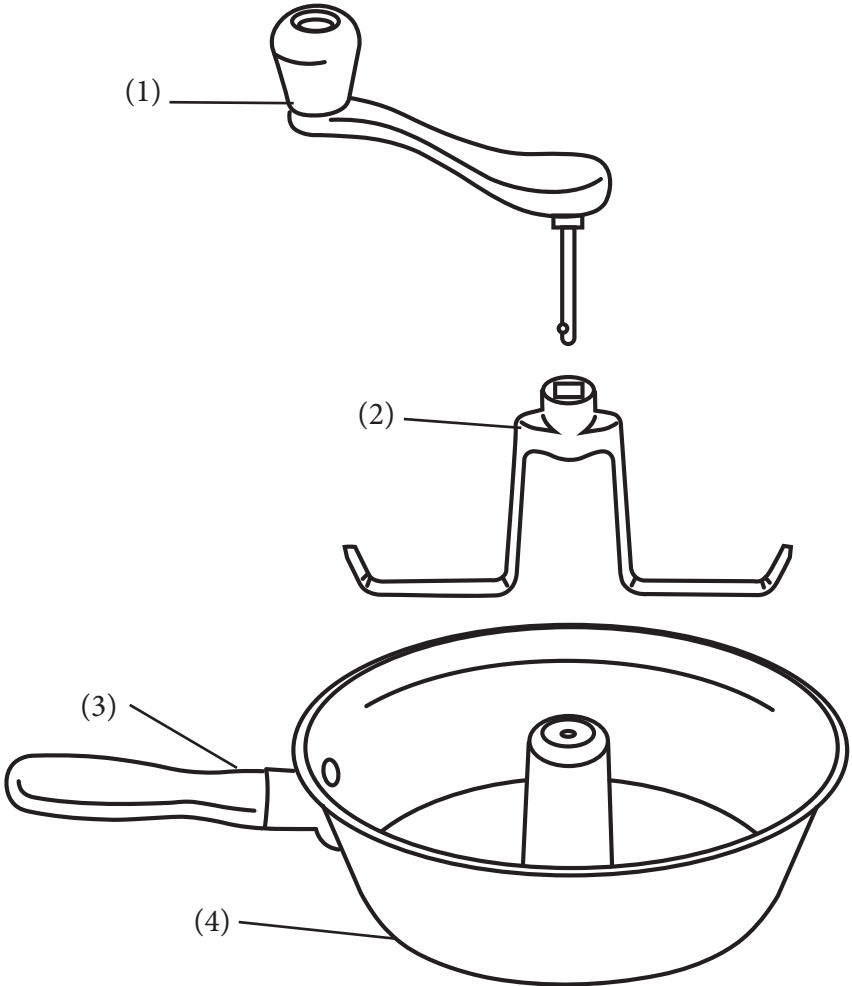

### **Parts List:**

- (1) Crank Handle
- (2) Stirring Blade
- (3) Handle
- (4) Pot

All replacement parts are available on our website, [VKPbrands.com](http://VKPbrands.com).

## Operating Precautions

To prevent personal injury or property damage, read and follow all instructions and warnings.

Do not use for other than intended use.

Do not operate if damaged in any manner. For service information see warranty page.

For household use only.

Do not place empty Nut Roaster on heated stove top as damage to Nut Roaster or stove top can result.

Do not leave Nut Roaster unattended while cooking.

Use caution when cooking and emptying contents of the Nut Roaster

as they are very hot.

## Cleaning Instructions

Before using for the first time, wash in warm, soapy water, rinse and dry thoroughly.

After use, allow the Nut Roaster to cool to room temperature before cleaning to avoid damaging it. Add hot water and dish liquid to the nut roaster to soak for several minutes to dissolve the sugar glaze on the pan and the stirring rod. Do not allow the Nut Roaster to soak in a sink filled with hot, soapy water as this may cause damage to the wooden handle.

Do NOT wash in the dishwasher.

## **Accessories**

Don't forget your Time for Treats Nut Glazes and Gift/Serving Bags. To purchase, visit our website, [VKPbrands.com](http://VKPbrands.com).



## Assembling Your Nut Roaster

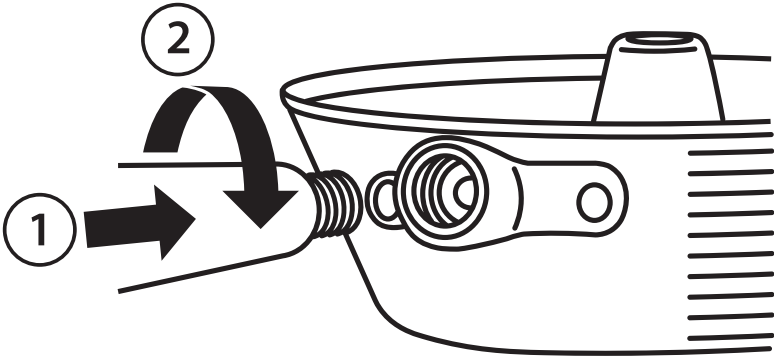

1. Insert handle into pot.
2. Turn handle clockwise until secure. Do not over-tighten.
3. Insert crank handle into the stirring blade. Be sure the rectangle parts fit together correctly.
4. Insert crank handle and stirring blade into pot and push firmly to secure.

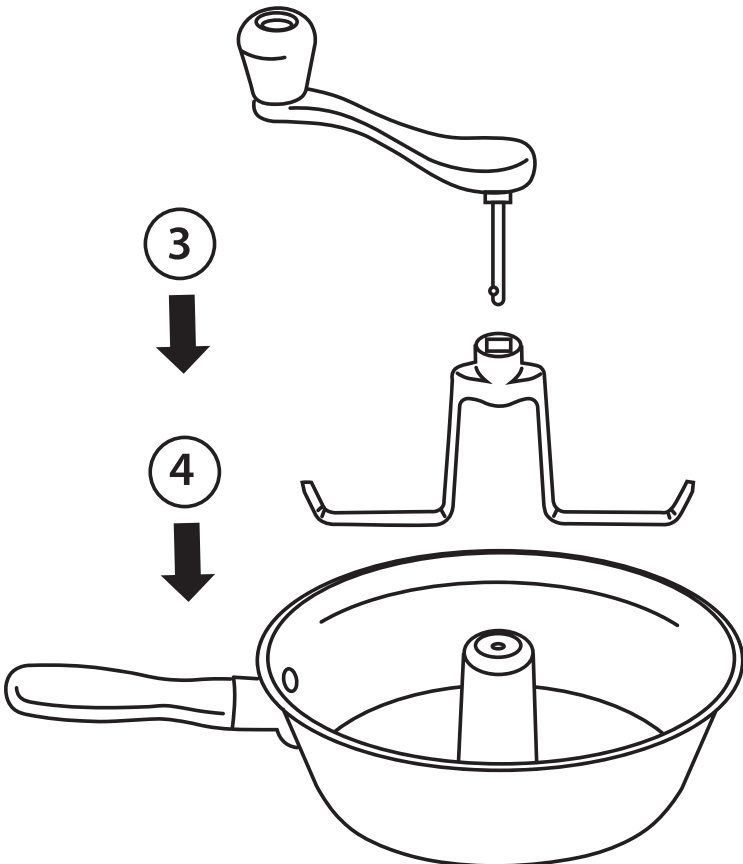

## Using Your Nut Roaster

NOTE: The maximum capacity for this Nut Roaster is 3 cups.

1. Spread your choice of nuts (almonds, peanuts, pecans, walnuts, cashews, or hazelnuts) evenly in the bottom of the pan.
2. Pour glaze evenly over the top of the nuts. Use glaze packaging instructions to determine amount to use.
3. Turn crank handle to mix the nuts and glaze together.
4. Place pan on burner and turn to medium heat.
5. Stir continuously and slowly. This allows the glaze to keep coating the nuts. It is normal for the nuts to slide around at first. They will begin to tumble as the glaze thickens.
6. As the glaze begins to thicken, you will feel more resistance as you stir the nuts. When all the liquid evaporates from the glaze, it will quickly change to a crystalline coating. Remove the pan from the heat.
7. Using a spatula, immediately spread the nuts on a non-stick baking tray, parchment paper, or silicone baking mat.
8. Separate the nuts with a wooden spoon as needed.
9. DO NOT attempt to eat the nuts until they are completely cooled. Sure, they smell amazing, but you will burn your tongue! Seriously, don't do it!

## Recipes

### **Spicy Maple Bacon Nuts**

Ingredients:

- 2 cups nuts
  - 1/4 cup pure maple syrup\*
  - 2 slices fully cooked bacon, crumbled
  - 1/8 tsp cayenne pepper (adjust to taste)
1. Spread nuts evenly on the bottom of the pan.
  2. Pour maple syrup evenly over the nuts and stir to coat.
  3. Sprinkle crumbled bacon and cayenne pepper over the coated nuts. Stir.
  4. Place pan on burner and set to medium.
  5. Stir continually until nuts crystallize.
  6. Pour nuts onto baking sheet to cool.
  7. Enjoy!

\*Any corn syrup based syrup will not crystallize and is not recommended.

## Honey Roasted Nut Brittle

Ingredients:

- 2 cups nuts
- 1/4 cup honey

1. Spread nuts evenly on the bottom of the pan.
2. Pour honey evenly over the nuts and stir to coat them.
3. Place pan on burner and set to medium-low. Note this is lower than normal as you'll be roasting longer than usual.
4. Stir continually for approximately 20 minutes. When the honey has browned just slightly, pour the nuts onto a baking tray to cool.
5. When fully cooled, break into pieces.
6. Enjoy!

## Spiced Mixed Nuts

Ingredients:

- 2 Tablespoons butter
- 1/2 teaspoon garlic salt
- 2 Tablespoons Worcestershire sauce
- Dash of onion powder
- 1/8 teaspoon hot pepper sauce
- 2 cups mixed nuts of your choice

1. Add first five ingredients to pan and heat on low.
2. Stir to mix thoroughly and add nuts when the butter is melted.
3. Increase heat to medium and continue stirring until nuts are completely warmed and coated.
4. If you prefer the nuts to be more crisp, place on a baking tray in 300 degree oven for 20 minutes.
5. Enjoy!

## **Product Warranty**

Register your warranty online at:  
**VKPbrands.com/Warranty**

Model VKP1225 - Deluxe Nut Roaster Warranty: 1 year

We are confident in the quality of our products and back each one with a limited warranty for the length of time specified above. Should you experience any problems with your product, please contact our Customer Service Department.

All warranty claims must be accompanied by a proof of purchase and are only valid if the appliance has been operated within the U.S. or Canada and used for its intended purposes. These products are for household use only.

### **Items Not Covered:**

- Return shipping costs or returned items lost in transit.
- Damages to the product due to accident, misuse, abuse, negligence, or if the appliance has been altered in any way.
- Products used outside of the United States or Canada.

# **VKP<sup>™</sup>**

**B R A N D S**

1804 Sandhill Rd

Orem UT, 84058

Phone: **866-257-4741**

**VKPbrands.com**

Time For Treats is a trademark of VKP Brands  
© Copyright 2020 VKP Brands, all rights reserved