



GARDEN™ STEAM JUICER

— ALUMINUM —
Instruction Manual



Table of Contents

| | |
|--|----|
| Parts Diagram..... | 3 |
| Operating Precautions..... | 4 |
| Product Overview..... | 4 |
| Care Instructions..... | 5 |
| Preparing Fruit for Juicing - General..... | 6 |
| Preparing Specific Fruit Types..... | 6 |
| Assembly & Use Instructions..... | 7 |
| Jar Sterilization..... | 10 |
| Juice Preservation..... | 10 |
| Recipes..... | 10 |
| Apple Juice..... | 11 |
| Grape Juice..... | 11 |
| Apple-Cinnamon Syrup..... | 12 |
| Berry Syrup..... | 12 |
| Blueberry Jelly..... | 13 |
| Grape Jelly..... | 13 |
| Peach Jelly..... | 14 |
| Plum Jelly..... | 15 |
| Pomegranate Jelly..... | 15 |
| Product Warranty..... | 16 |

*For the most up-to-date manual, or for more information regarding this product, visit our website: **VKPbrands.com**

Aluminum Steam Juicer Model VKP1148

Parts Diagram

Your complete steam juicer includes everything shown below:

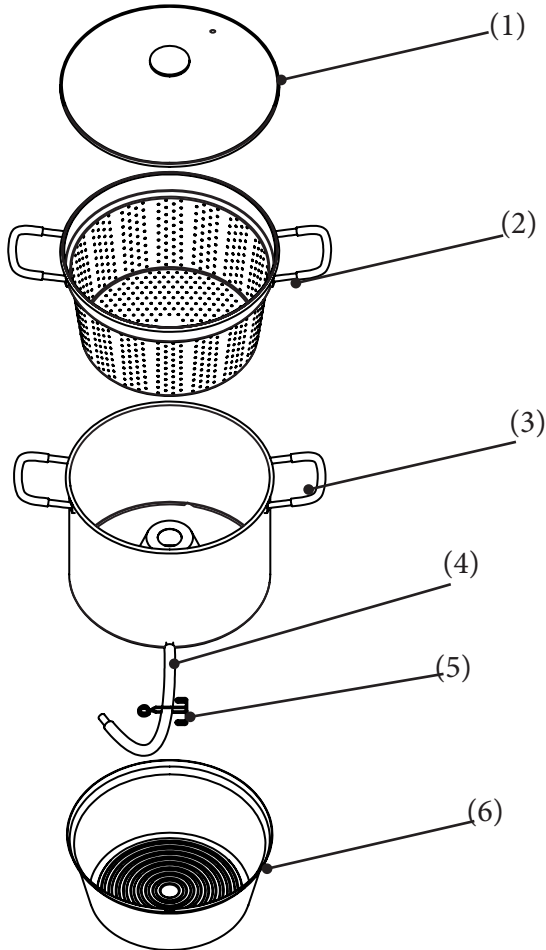

Parts List:

- (1) VKP1148-1 Lid
- (2) VKP1148-3 Colander
- (3) VKP1148-4 Juice Kettle
- (4) VKP1140-6 Hose with Metal Tip
- (5) VKP1140-5 Spring Clamp
- (6) VKP1148-2 Water Pan

All replacement parts are available on our website, VKPbrands.com.

Operating Precautions

TO PREVENT PERSONAL INJURY AND TO PREVENT DAMAGE TO YOUR STEAM JUICER, PLEASE READ AND FOLLOW ALL OF THE FOLLOWING INSTRUCTIONS AND WARNINGS:

- **Do NOT** use soft water in the water pan due to the trace amounts of salt from the water softener that will concentrate and become corrosive to the aluminum leading to pitting and even holes. Always fill the water pan with water that has not gone through a water softener.
- Always use heat protective gloves or mitts when handling any part of your juicer.
- When removing the lid from the steam juicer, be sure to always tilt it away from you to avoid steam burns.
- Any steam produced will be hot and can cause a serious burn injury. Use extreme caution while using your juicer.
- **Do NOT** let the water pan boil dry, this will cause damage to the water pan and could also damage your stove top. Check the water level often. Place 2 marbles in the water pan with the water and when the marbles stop making noise, it is time to add more water.
- Never leave your steam juicer unattended while in use.
- Do not use by or near children.
- For household use only.
- **Do not put any portion of the steam juicer in a dishwasher.**

Product Overview

Congratulations on your purchase of the Steam Juicer!

In this manual you will find assembly instructions, how to prepare specific types of fruit for juicing, how to use your juicer, and a recipes section.

To give you a good idea of the basic procedure, you will start by washing and assembling your juicer and selecting good quality fruit. Next, fill the water pan with water, and once the fruit is properly prepared, you will add it to the colander portion of the juicer. As the water boils, the hot steam will rise up through the colander, heat the fruit and begin the extraction process.

The juice will drip down into the juice kettle, and in approximately one hour, you can start to drain healthy, vitamin-rich juice into a pot to be used for juice concentrates, jellies, syrups and more.

Steam Juicer Liquid Capacities:

- Water Pan - 6 Qt
- Juice Kettle - 4.5 Qt
- Colander - 10 Qt

Care Instructions

Use a soft cloth and warm, soapy water to wash your Steam Juicer by hand before the initial use (**never put any portion of your steam juicer in a dishwasher**). This will help to remove any particles or residue from the factory. Then follow these simple care instructions for keeping your steam juicer clean:

- Whenever you wash your juicer, be sure to use a soft cloth to keep from scratching the surface.
- If hard water builds up on any portion of your steam juicer, those are easily cleaned by soaking the affected portion in a diluted vinegar solution. Use ½ c. vinegar to 1 qt of water and let soak for 30-60 minutes. Use a dishcloth to wash off any remaining hard water, rinse and dry. You may need to increase the soak time and/or the amount of vinegar used for tough buildup.
- Once clean, dry the juicer with a soft dishtowel to keep water spots from forming.
- Keep the juicer in its original packaging material when not in use. This will keep it protected and free from dust or other particles.
- ***NOTE** - Avoid using harsh chemicals on the aluminum surface. Some discoloration or staining will occur once the aluminum has been exposed to heat. This is normal and cannot be reversed. However, this will not affect the functionality of your steam juicer.

Preparing Fruit for Juicing - General

Select fruit that is of the appropriate ripeness for the recipe you will be using, is firm, has a good color and texture, and is of ideal quality for eating fresh or cooking. Any fruit that has molded, is bruised, split or has otherwise been compromised should be discarded, or the damaged section cut away. **Using fruit that is overripe will cause your juice to have a watery flavor.** Quartering larger fruit, like apples and peaches, can help accelerate the overall juicing process because it allows the fruit to release its liquid more quickly. For fruit with stems, thicker rinds and pits that would not normally be consumed when eating fresh, you will need to remove these portions beforehand, otherwise you may end up with bitter or unwanted flavors in your juice.

Preparing Specific Fruit Types

- **Berries & Grapes** – To prepare this type of fruit, you will need to remove all stems and discard any damaged fruit. Wash the fruit thoroughly, then place in the colander of the steam juicer.
- **Fruits with Cores** – These are fruits containing a core like apples and pears. Once the fruit has been washed and checked for blemishes, you will need to remove the stems, cut into quarters, and place in the colander of the steam juicer. There is no need to remove cores and seeds from this type of fruit.
- **Stone Fruit** - When preparing fruit that has stones like peaches, plums, apricots, nectarines, etc, you should remove the stones before juicing. Once the produce has been washed and checked for blemishes, you will need to remove the stone. Cut fruit into halves or quarters, depending on size, and place in the colander portion of the steam juicer.
- If you are juicing any fruit that doesn't fall within these three categories, the main thing to remember is if there are portions you would not normally consume while eating fresh, then do not put that into the juicer. This could result in the finished juice having an undesirable flavor.

Assembly & Use Instructions

Please make sure you have read through the sections - Operating Precautions (p. 4) and Preparing Specific Fruit Types (p. 6) - before assembling and using your juicer.

Juicer Assembly & Use:

1. Remove your new Steam Juicer from the box and packaging and check that all items are there and in good condition. Refer to the diagram on p. 3 for help, if needed.
2. Wash all parts of the juicer thoroughly by hand in warm soapy water and rinse carefully. **Do NOT** wash in dishwasher and **do NOT** attempt to remove the hose from the juice kettle.
3. Once clean, take the water pan and fill it with 5 quarts of fresh water and place it on your stove top. (See Operating Precautions regarding water softeners on pg. 4.)
4. Next, place the juice kettle on top of the water pan so the juice hose can fall lower than the juice kettle. If the hose is raised too high, the juice will not drain properly.

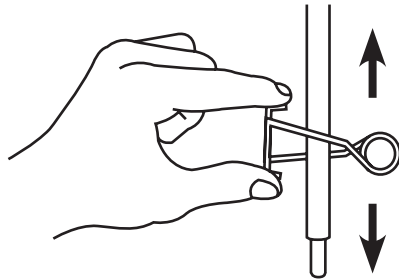

5. Squeeze the clamp and slide it to the center of the hose. (See diagram below.)
6. Then, place the colander on top of the juice kettle and fill it to the top with previously prepared fruit. (Refer to p. 6 for proper fruit preparation methods). The colander holds approximately 8-9 quarts of fruit pieces. **Make sure the fruit does not overflow the colander.**

7. Put the lid on top of the colander, making sure it fits securely in place. If it does not, you may need to remove any excess fruit.
8. After correctly assembling your juicer, turn on the burner unit to the high position. **BE SURE TO ALWAYS USE HEAT PROTECTIVE GLOVES OR MITTS WHILE WORKING WITH YOUR JUICER. THE STEAM IS VERY HOT AND WILL BURN YOU.**
9. Once the water has come to a rapid boil, begin turning down your burner temperature until the water remains at a consistent rolling boil, but not too vigorous.
10. **DO NOT LET THE WATER PAN BOIL DRY. CHECK THE WATER LEVEL OFTEN AND ADD MORE WATER AS NEEDED. DO NOT LEAVE YOUR STEAM JUICER UNATTENDED WHILE IT IS IN USE.**
11. You will need a pot or canning jars ready for the juice to drain into. Place it slightly below the juicer so the juice hose hangs down into the pot by 3-4 inches. (See diagram below). It will take approximately 1 hour before there is enough juice in the juice kettle to drain.

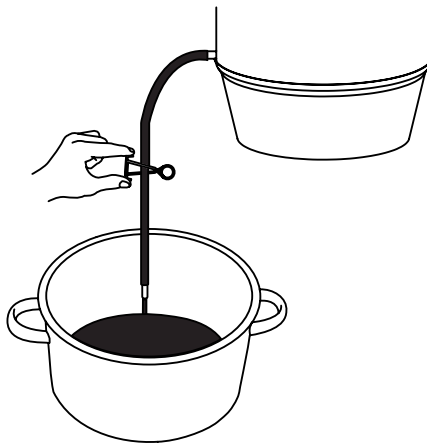

12. It will take approximately 2-3 hours for one batch of fruit to go through the entire juicing process. However, times may vary depending upon your burner temperature, altitude and the type of fruit you use.
13. **Stirring the fruit is not recommended as that will result in cloudy juice.** For clean, clear-looking juice it is best to leave the fruit untouched during the juicing process.
14. You can check for juice one of two ways: First, carefully squeeze open the hose clamp and juice will automatically begin draining into the saucepot if there is enough. Second, lift the juice hose straight up by holding onto the clamp. **DO NOT TOUCH THE HOSE AS IT WILL BE VERY HOT.** If you do not see any juice in the hose, then there is not enough juice in your juice kettle to be measured, using this method. (See diagram below).

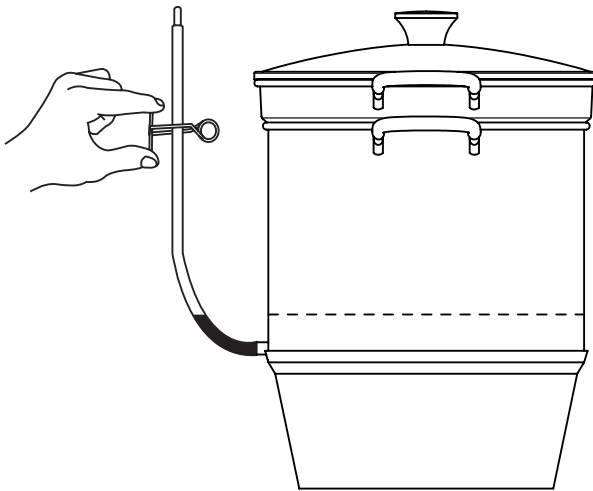

15. If you will be juicing several batches of fruit in a row, be sure to juice one colander full at a time and remove waste before adding another batch for optimal performance. Be sure you do not wait too long before draining the juice kettle, as the juice could overflow into the water pot below. The juice kettle holds up to 4.5 quarts of juice.

Jar Sterilization

According to the USDA, all jams, jellies, juices and pickled products processed for less than 10 minutes in a water bath canner should be filled into sterile empty jars.

To sterilize empty jars after washing in soap and rinsing thoroughly, submerge them, right side up, in a boiling-water canner with the rack in the bottom. Fill the canner with enough warm water so it is 1 inch above the tops of the jars. Bring the water to a boil, and boil 10 minutes at altitudes of less than 1,000 ft. At higher elevations, boil 1 additional minute for each additional 1,000 ft elevation. Reduce the heat under the canner, and keep the jars in the hot water until it is time to fill them. Remove and drain hot sterilized jars one at a time, saving the hot water in the canner for processing filled jars. Fill the sterilized jars with food, add lids, and tighten screw bands.

Juice Preservation

Once you have finished the juicing process you can use your juice for several different things. You can consume it immediately and store the remaining amount in your refrigerator for up to 1 week. You can preserve it by freezing it in containers, or canning it in a water-bath canner. Or, you can use the juice for syrups and jellies (see recipe section p. 12 - 15).

Preserving Juice by Water-Bath Canning: For instructions on how to properly and safely use a water-bath canner, please consult the USDA's Complete Guide to Home Canning, "Guide 1, Principles of Home Canning." You can also find this information on the National Center for Home Food Preservation website at: <http://nchfp.uga.edu>. Click on the 'Publications' link then on 'U.S. Department of Agriculture.'

Recipes

These recipes are for fruit juices, syrups and jellies that can be made with the finished product from your steam juicer. All recipes were taken from USDA approved sources: USDA's Complete Guide to Home Canning, the University of Georgia's So Easy to Preserve, and Ball's Blue Book, Guide to Preserving. While some of the wording has been changed to adapt them for use with your Steam Juicer, the ingredient amounts and processing times are the same. **(Please adjust time based on your altitude. If you are unsure of your altitude level, please contact your local extension office.)**

Apple Juice

Quantity: For a canner load of 7 quarts, you will need about 28-30 pounds of apples. Approximately 4 pounds of fruit yield 1 quart (4 cups) of juice.

Quality: Good quality apple juice is made from a blend of varieties. For best results, use apples that are firm, have a good color, and are at the peak of their sweetness. Overripe fruit of any kind will result in watery juice.

Procedure: Once you have finished juicing your apples (refer to p. 6 for juicing instructions) measure the amount you would like to preserve and pour into a large, heavy bottom saucepan. Heat quickly, stirring occasionally until juice begins to boil. Fill immediately into hot, sterile quart jars, leaving ¼-inch headspace. Wipe rims of jars with a dampened clean paper towel. Adjust lids and tighten rings finger-tip tight ONLY. Then, process in a water-bath canner for 5 minutes. **(Please adjust time based on your altitude. If you are unsure of your altitude level, please contact your local extension office.)**

**This recipe has been adapted from the apple juice recipe in the USDA's Complete Guide to Home Canning, section 2-6*

Grape Juice

Quantity: An average of 24-1/2 pounds of grapes are needed per canner load of 7 quarts; an average of 16 pounds per canner load of 9 pints. A lug weighs 26 pounds and yields 7-9 quarts of juice – an average of 3-1/2 pounds per quart.

Quality: Select sweet, well-colored, firm, mature fruit of ideal quality for eating fresh or cooking.

Procedure: Once you have finished juicing your grapes (refer to p. 6 for juicing instructions), measure the amount you would like to preserve and pour into a large, heavy bottom saucepan. Then sweeten to taste. Heat and stir until sugar is dissolved and juice begins to boil. Fill immediately into hot, sterile quart jars (refer to p. 10 for proper sterilization instructions), leaving ¼-inch headspace. Wipe rims of jars with a dampened clean paper towel. Adjust lids and tighten rings finger-tip tight ONLY. Then, process in a water-bath canner for 5 minutes. **(Please adjust time based on your altitude. If you are unsure of your altitude level, please contact your local extension office.)**

**This recipe has been adapted from the grape juice recipe in the USDA's Complete Guide to Home Canning, section 2-15.*

Apple-Cinnamon Syrup

Yield: About 6 pints.

Ingredients:

6 c. apple juice
4 c. water
3 sticks cinnamon, broken
3 c. corn syrup
5 c. sugar
¼ c. lemon juice

Procedure: Once you have finished juicing your apples (refer to page 6 for juicing instructions) measure 6 cups of juice into a medium saucepot, then add the cinnamon sticks. Simmer 5 minutes; set aside. Combine sugar and water in a medium saucepot; boil to 230° F (adjust for altitude). Add apple juice, cinnamon sticks and corn syrup to sugar syrup. Boil 5 minutes. Remove cinnamon sticks. Stir in lemon juice. Ladle hot syrup into sterile jars, (refer to p. 10 for proper sterilization instructions), leaving ¼-inch headspace. Wipe rims of jars with a dampened clean paper towel. Adjust lids and tighten rings finger-tip tight ONLY. Then, process in a water-bath canner for 10 minutes. **(Please adjust time based on your altitude. If you are unsure of your altitude level, please contact your local extension office.)**

**This recipe has been adapted from the apple-cinnamon syrup recipe in Ball's Blue Book, Guide to Preserving, 100th Anniversary Edition, p. 82.*

Berry Syrup

Yield: About 9 half-pints.

Ingredients:

5 c. Berry Juice
6 ¾ c. Sugar

Procedure: Once you have finished juicing the berries of your choice (refer to p. 6 for juicing instructions), measure 5 cups of juice into a large, heavy bottom saucepan. Combine the juice with 6 ¾ cups of sugar, bring to a boil, and simmer 1 minute, stirring occasionally. Remove from heat, skim off foam, and fill into sterile half-pint jars, (refer to p. 10 for proper sterilization instructions), leaving 1/2-inch headspace.

Remove air bubbles and adjust headspace if needed. Wipe rims of jars with a dampened, clean paper towel. Adjust lids and tighten rings finger-tip tight ONLY. Then, process in a water-bath canner for 10 minutes. **(Please adjust time based on your altitude. If you are unsure of your altitude level, please contact your local extension office.)**

*This recipe has been adapted from the berry syrup recipe in the USDA's Complete Guide to Home Canning, section 2-10.

Blueberry Jelly

Yield: 7-8 half-pint jars.

Ingredients:

4 c. Blueberry Juice

7 ½ c. Sugar

2 Pouches Liquid Pectin

Procedure: Once you have finished juicing your blueberries (refer to p. 10 for juicing instructions), measure 4 cups of juice into a large saucepot. Stir in sugar. Place on high heat; stir constantly and bring to a full rolling boil that cannot be stirred down. Add the liquid pectin and heat again to a full rolling boil. Boil hard for 1 minute. Remove from heat; quickly skim off foam. Pour jelly immediately into sterile half-pint jars, (refer to p. 6 for proper sterilization instructions), leaving ¼-inch headspace. Wipe rims of jars with a dampened clean paper towel. Adjust lids and tighten rings finger-tip tight ONLY. Then, process in a water-bath canner for 5 minutes. **(Please adjust time based on your altitude. If you are unsure of your altitude level, please contact your local extension office.)**

**This recipe has been adapted from the blueberry jelly with liquid pectin recipe from The University of Georgia's So Easy to Preserve, p. 199.*

Grape Jelly

Yield: Approx. 5 half-pints

Ingredients:

3 c. Grape Juice

1 Package Powdered Pectin

4 ½ c. Sugar

Procedure: Once you have finished juicing your grapes (refer to p. 6 for juicing instructions), measure 4 cups of juice into a large saucepot. Add powdered pectin to juice and bring to a boil over high heat. Add sugar, stirring until dissolved. Return to a boil. Boil hard for 1 minute, stirring constantly. Remove from heat and quickly skim off foam. Ladle jelly immediately into sterile half-pint jars, (refer to p. 10 for proper sterilization instructions), leaving ¼-inch headspace. Wipe rims of jars with a dampened clean paper towel. Adjust lids and tighten rings finger-tip tight **ONLY**. Process in a water-bath canner for 10 minutes. (**Please adjust time based on your altitude. If you are unsure of your altitude level, please contact your local extension office.**)

Peach Jelly

Yield: 5-6 half-pint jars.

Ingredients:

3 c. Peach Juice

5 c. Sugar

½ c. Lemon Juice

1 Box Powdered Pectin

Procedure: Once you have finished juicing your peaches (refer to p. 6 for juicing instructions), measure 3 cups of juice into a large saucepot. Measure sugar and set aside. Add powdered pectin and lemon juice to previously measured juice in saucepot. Bring to a full boil over high heat, stirring constantly. Immediately stir in sugar. Bring to a full rolling boil that cannot be stirred down. Boil hard for 1 minute, stirring constantly. Remove from heat and quickly skim off foam. Ladle jelly immediately into sterile half-pint jars, (refer to p. 10 for proper sterilization instructions), leaving ¼-inch headspace. Wipe rims of jars with a dampened clean paper towel. Adjust lids and tighten rings finger-tip tight **ONLY**. Process in a water-bath canner for 5 minutes. (**Please adjust time based on your altitude. If you are unsure of your altitude level, please contact your local extension office.**)

**This recipe has been adapted from the peach jelly with powdered pectin recipe from The University of Georgia's So Easy to Preserve, p.202.*

Plum Jelly

Yield: 7-8 half-pint jars.

Ingredients:

5 ½ c. Plum Juice (about 5 pounds)

7 ½ c. Sugar

6 Tbsp. Powdered Pectin

Procedure: Once you have finished juicing your plums (refer to p. 6 for juicing instructions), measure 5 ½ cups of juice in a large stockpot. Combine pectin with juice and bring to a boil over high heat, stir frequently. Add sugar, stirring until dissolved. Return to a rolling boil. Boil hard one minute, stirring constantly. Remove from heat. Skim foam if necessary. Ladle hot jelly into hot jars, leaving ¼ inch headspace. Wipe rims of jars with a dampened clean paper towel. Adjust lids and tighten rings finger-tight ONLY. Process 10 minutes in a waterbath canner. **(Please adjust time based on your altitude. If you are unsure of your altitude level, please contact your local extension office.)**

Pomegranate Jelly

Yield: 5-6 half-pint jars.

Ingredients:

3 ½ c. Pomegranate Juice (about 5 pounds) 5 c. Sugar

6 Tbsp. Powdered Pectin

Procedure: Once you have finished juicing your plums (refer to p. 6 for juicing instructions), measure 3 ½ cups of juice in a large stockpot. Combine pectin with juice and bring to a boil over high heat, stir frequently. Add sugar, stirring until dissolved. Return to a rolling boil. Boil hard one minute, stirring constantly. Remove from heat. Skim foam if necessary. Ladle hot jelly into hot jars, leaving ¼ inch headspace. Wipe rims of jars with a dampened clean paper towel. Adjust lids and tighten rings finger-tight ONLY. Process 10 minutes in a waterbath canner. **(Please adjust time based on your altitude. If you are unsure of your altitude level, please contact your local extension office.)**

**These recipes have been adapted from the pomegranate jelly recipe in Ball's Blue Book, Guide to Preserving, 100th Anniversary Edition, p. 36.*

Product Warranty

Register your warranty online at:
VKPbrands.com/Warranty

Model VKP1148 - Garden Steam Juicer Warranty: 5 years

We are confident in the quality of our products and back each one with a limited warranty for the length of time specified above. Should you experience any problems with your product, please contact our Customer Service Department.

All warranty claims must be accompanied by a proof of purchase and are only valid if the appliance has been operated within the U.S. or Canada and used for its intended purposes. These products are for household use only.

Items Not Covered:

- Return shipping costs or returned items lost in transit.
- Damages to the product due to accident, misuse, abuse, negligence, or if the appliance has been altered in any way.
- Products used outside of the United States or Canada.

VKP™

B R A N D S

1804 Sandhill Rd

Orem UT, 84058

Phone: **866-257-4741**

VKPbrands.com