



**Roots &  
Branches™**

Preserving The Tradition

---

# **FRUITSAVER™ STEAM CANNER**

## **Instruction Manual**



## Table of Contents

Canner Capacity .....	2
Parts Diagram .....	3
Assembly Instructions .....	4
Operating Precautions .....	6
Product Overview .....	7
Care Instructions .....	7
Jar Sterilization .....	8
Indicator Knob Instructions.....	8
Temperature Indicator Test .....	9
Canner Use Instructions .....	10
Processing Times.....	11
Troubleshooting Guide .....	12
Canning Jar and Lid Selection .....	12
Recipes .....	13
Spiced Apple Rings.....	13
Grapefruit & Orange Sections .....	14
Tomatillo Green Salsa.....	15
Product Warranty .....	16

### Canner Capacity

- 8 Pint Jars
- 7 Quart Jars

\*For the most up-to-date manual, or for more information regarding this product, visit our website: **VKPbrands.com**

# FRUITSAVER Model VKP1054

## Parts Diagram

Your complete steam canner includes everything shown below:

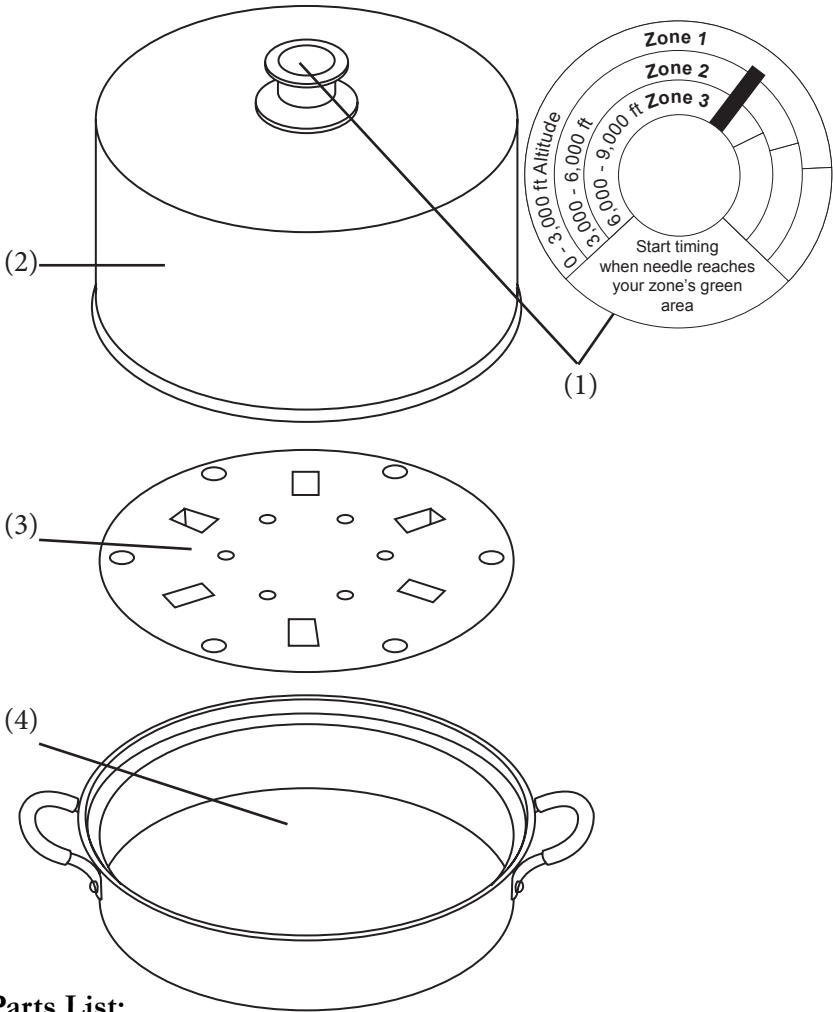

### Parts List:

- (1) VKP1054-4 Temperature Indicator
- (2) VKP1054-3 Lid - includes Temperature Indicator
- (3) VKP1054-2 Rack
- (4) VKP1054-1 Water Pan

All replacement parts are available on our website, [VKPbrands.com](http://VKPbrands.com).

# Assembly Instructions

Assemble in the order shown below.

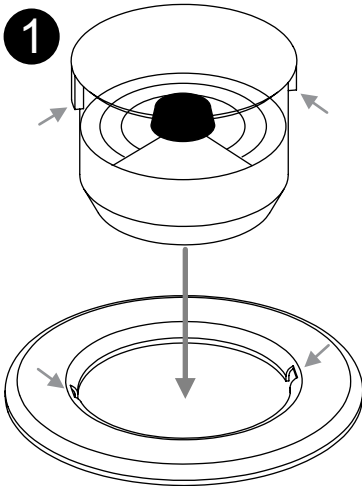
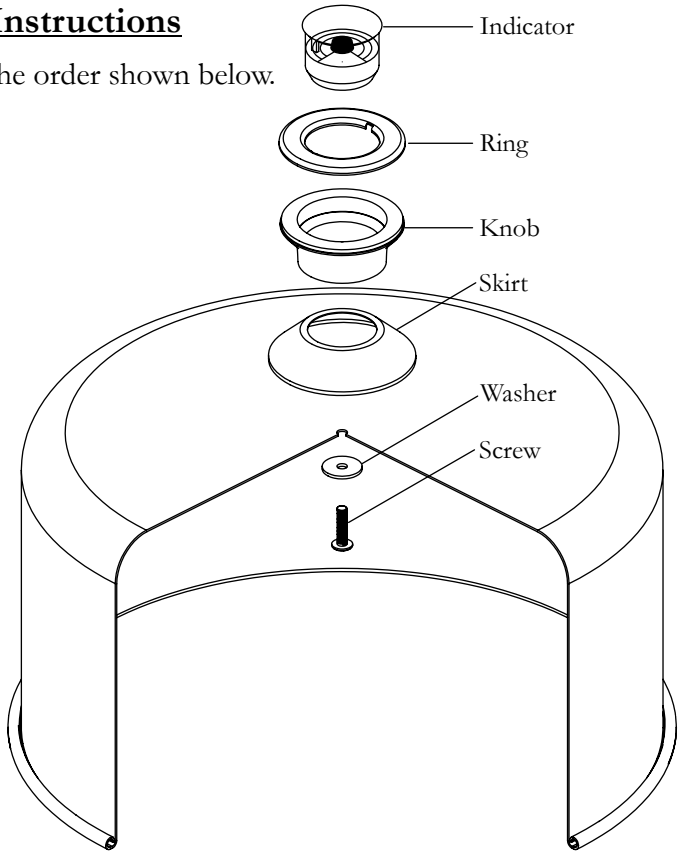

Line up indicator into the ring so notches line up and indicator sits flush in ring.

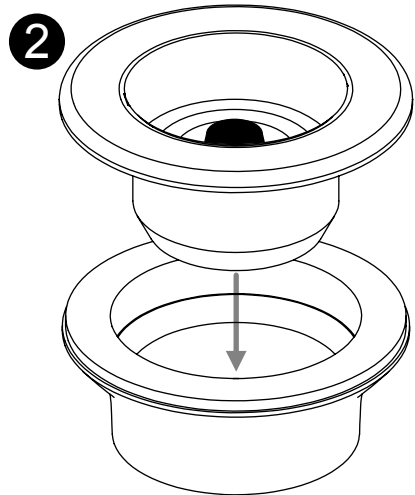

Assemble indicator with ring into knob.

3

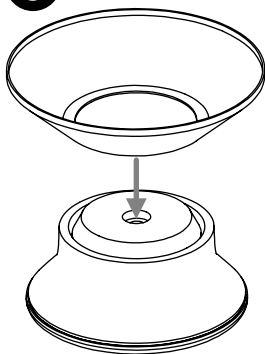

Turn the assembled knob upside-down on a table and place the skirt centered on top.

4

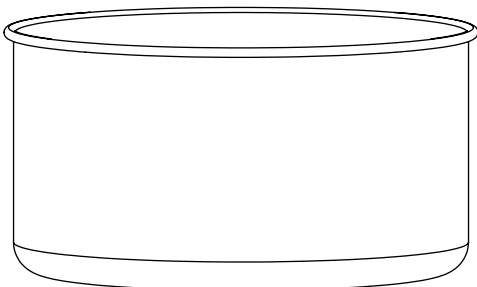

Slowly lower the lid (looking through the screw hole) ensuring it aligns with the indicator hole) until it sits on top of the knob.

5

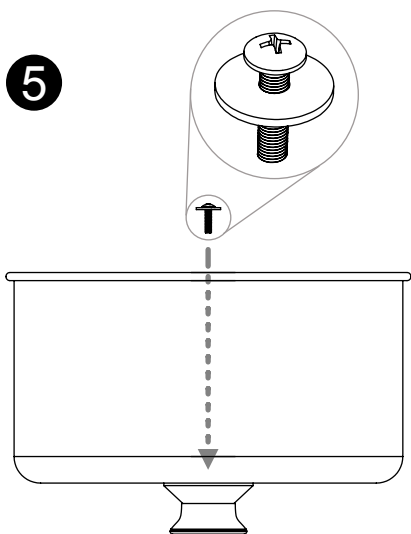

Place the aluminum screw through the washer and loosely tighten the screw using a Philips screw driver.

**Note:** Must use aluminum screw that is provided with the knob for indicator knob to work correctly. If you have trouble please contact customer service at 866-257-4741.

6

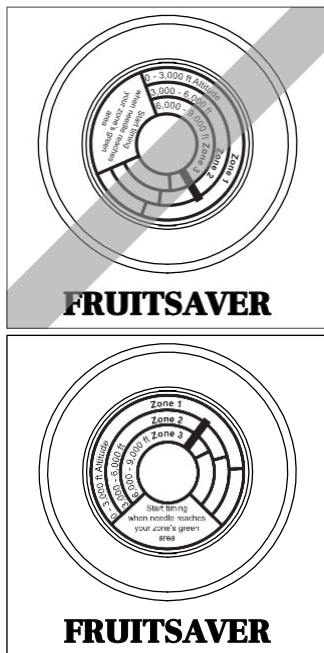

Adjust the knob aligning the indicator text with the logo on top of the lid, then securely tighten the screw. Be careful not to over-tighten.

## Operating Precautions

**WARNING! To prevent personal injuries, please read and follow all instructions correctly.**

- Steam canners and boiling-water canners are not to be used for canning low-acid foods, such as vegetables and meats. Low-acid foods must be processed in a pressure canner.
- Be certain your range or cooktop is rated for home canning. Some models of ranges or cooktops cannot be used for home canning, - especially smooth top ranges– since they can be damaged. Check with the manufacturer of your cooktop before using your canner. VKP Brands IS NOT responsible for damage of any kind to the range or cooktop as a result of using this canner.
- Always use heat protective gloves or mitts when handling any part of your canner.
- Any steam produced will be hot and can cause serious injury. Use extreme caution while using your canner.
- When removing the lid from the canner, be sure to always tilt it away from you to avoid steam burns.
- Never leave your canner unattended while it is in use.
- Check the water level in the water pot after every batch. **DO NOT LET THE WATER PAN BOIL DRY.** This will cause serious damage to your canner and may render it unusable. Your stove top could also be damaged if this happens.
- Using softened water may cause damage to the water pan over extended use. Most water softeners use salts which, when continually concentrated through use, may cause corrosion of the metal. This can be avoided by starting with cold water, as most home water softeners do not soften the cold water lines to the kitchen sink.
- Do not use by or near children.

## Product Overview

Congratulations on your purchase of the FruitSaver Steam Canner! This manual will help you use your canner properly and understand its features. However, this manual is NOT a general guide to home canning. If you do not have a USDA approved home canning guide, visit their website at [nchfp.uga.edu](http://nchfp.uga.edu), for more information. You can also visit our website, [VKPbrands.com](http://VKPbrands.com), where you'll find resources for approved home canning procedures. Don't forget, you can also check with your local Extension Office for helpful canning advice and your local altitude (see the Troubleshooting Guide for more information on p. 12).

- **Steam & Water Bath Canning Differences:** Water bath canning is the process of immersing the jars in water and using the boiling water to raise the temperature of the jars. Steam canning is the process of boiling the water below the jars and using steam to heat the jars. The advantage to steam canning is that it saves time, energy and water. As a result, steam canning is a much quicker and more efficient method.
- **Aluminum Jar Rack:** The Steam Canner has an aluminum jar rack that is flat, stable and sits securely inside the water pan. The rack will hold 8 pint jars or 7 quart jars.

## Care Instructions

Use a soft cloth and warm, soapy water to wash your Steam Canner by hand before the initial use. This will help to remove any particles or residue from the factory. Do NOT wash in the dishwasher. Then follow these simple care instructions to keep your canner clean:

- After each use, wash the water pan, lid and jar rack in warm, soapy water. Rinse and dry well. Be sure to use a soft cloth to keep from scratching the aluminum surface. Do NOT wash in the dishwasher.
- As the canner is used, you may notice hard water buildup as well as discoloration or darkening of the bottom pot. This is normal for aluminum.
- To remove hard-water deposits from the bottom pot, add 1/8 cup of vinegar and 2 quarts of water to the pot and boil for 2 to 3 minutes.
- **NEVER ALLOW YOUR CANNER TO BOIL DRY.** Negligence might result in damage to the canner or your stove. Check the water level after every batch. (See #2 on page 10).

# Jar Sterilization

According to the USDA, all jams, jellies, juices and pickled products processed for less than 10 minutes in a water bath canner should be filled into sterile empty jars.

To sterilize empty jars after washing in soap and rinsing thoroughly, submerge them, right side up, in a boiling-water canner with the rack in the bottom. Fill the canner with enough warm water so it is 1 inch above the tops of the jars. Bring the water to a boil, and boil 10 minutes at altitudes of less than 1,000 feet. At higher elevations, boil 1 additional minute for each additional 1,000 feet of elevation. Reduce the heat under the canner, and keep the jars in the hot water until it is time to fill them. Remove and drain hot sterilized jars one at a time, saving the hot water in the canner for processing filled jars. Fill the sterilized jars with food, add lids, and tighten screw bands.

## Indicator Knob Instructions

**WARNING! Be careful where you place your canner lid. DO NOT set the lid on top of hot burners or hot pans as this can cause the indicator to give inaccurate readings or be damaged.**

Your Canner has an indicator built into the knob on the lid. This indicator tells you when to start your processing time. The indicator has 3 different “Zones”. The zones are divided into altitude ranges. In order to properly use the indicator, you will need to know what your altitude is so that you can determine which “Zone” you need to use. If you don’t know your altitude level, you can **contact your local Extension Office** (see the Troubleshooting Guide for more information on p. 12).



### **Why do I need to know the altitude where I am canning?**

Because water boils at lower temperatures the higher you are from sea level. To put it another way, the higher your altitude, the lower the boiling point will be.

### **How does the indicator work?**

The indicator measures the temperature of the steam inside the canner. When the temperature inside the canner reaches the processing temperature (boiling) the indicator will reach the green area for your zone. You may also see steam escaping around the lid as another indicator that the canner is up to the correct temperature.



NOTE: The “Zones” on the indicator are approximations for the different altitudes. Before using the canner, please follow the instructions below to calibrate the indicator for your exact altitude. This testing procedure is very important and will enable you to know precisely when to start your processing time to avoid under-or over-processing of your canned foods.

## **Temperature Indicator Test**

The Temperature Indicator should be tested and calibrated prior to initial and seasonal use of your Steam Canner.

- Follow canner instructions on p. 10, except skip steps 3 & 4 and use only four one-quart jars filled with water; the jars do not need lids. The four jars simulate the contents of your canner in actual use but enable it to get up to temperature quicker.
- It will take about 20 – 45 minutes to come up to full temperature and complete the test. The time it takes depends upon the stove that is used and heat that is applied.
- If the lid starts lifting up, rattling or spitting water from around the edges, this is an indication that it is almost up to temperature and you need to slowly turn the heat down until these actions stop.
- Continue to watch the indicator until the red needle stops rising. The indicator should reach the green area for your “Zone” but can vary from just reaching the green area to going far inside it. This is because the “Zones” are approximate and your exact altitude will affect the maximum position of the indicator.
- Record this maximum point by marking it on the indicator knob, making a note or taking a picture. This is the point at which your canner is up to boiling temperature and it is safe to start the processing time.
- To ensure that each batch is properly processed, be sure to wait to start the processing time until the indicator reaches this point.
- For best results, this test should be repeated each year before you begin your canning, note any changes in the indicator reading from the prior year. This test will also need to be done each time your canner is used in a new location, as elevation changes will cause the indicator to read differently.
- Replacement indicators are available at [VKPbrands.com](http://VKPbrands.com)

## Canner Use Instructions

Please make sure you have read through all of the instructions up to this point and performed the temperature indicator test on p. 9 before using your canner.

**Warning!** The steam and water will be hot and can cause a serious burn injury. Use extreme caution while using your canner.

Processing times for steam canning are the same as water-bath canning times.

**DO NOT let the canner boil dry.** Check water level after each batch and add more if needed.

**DO NOT remove lid during processing.** Removing the lid allows the steam to escape and the jars will no longer be at the correct temperature. If the lid is removed during processing you will need to bring the canner back up to the proper heat level and restart the processing time to ensure the jar contents are processed correctly.

1. Place rack in water pan with flat side up.
2. Fill the water pan with approximately 2-1/2 quarts of water. The water should be level with the top of the jar rack. (see diagram at right)

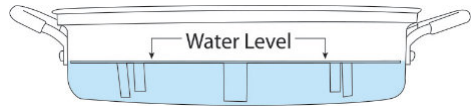

3. Preheat water to 140° F for raw-packed foods and to 180° F for hot-packed foods.
4. Follow the directions in an approved canning guide to prepare and fill the jars with the product you are going to process.
5. Place your prepared jars on the canning rack. It will hold 7 quarts or 8 pints.
6. Place the lid on the water pan so the vent hole is towards the back and you can easily read the indicator knob.
7. Make sure you know which “Zone” you are in according to your altitude. If you do not, contact your local Extension office (see the Troubleshooting Guide for more information on p. 12).
8. Turn your burner up so the water comes to a vigorous boil.
9. Start your processing time when the needle reaches the maximum point as recorded from the temperature indicator test on p. 9 Be sure your

processing time is from an approved canning guide to ensure you have a safe finished product. (The processing times for steam canning are the same as for water bath canning).

10. Adjust the burner so that it maintains an even rolling boil throughout the entire processing time. Usually this will be much lower than where it was set for step 8 when the water was coming up to a boil. If the top lid is lifting up and /or spitting water from the edges this is an indication that you have the heat turned up too high. Slowly reduce the heat until this stops. You only need enough heat to maintain a slow rolling boil. Watch the indicator to ensure the temperature does not decrease.
11. When the processing time is finished, turn off the heat and let the canner stand for 5 minutes with the lid on before removing jars. The lid **MUST** remain ON the canner during this time. This cool-down period is necessary to ensure the jar contents are properly processed. Removing the lid or skipping this step entirely can result in under-processed food.
12. Carefully remove the lid by tilting it away from you to avoid steam burns. **WARNING!** The steam and water will be hot and can cause a serious burn injury. Use extreme caution while using your canner.
13. Use hot pads or a jar lifter to remove the jars from the canner. Place the jars on a dry towel, cloth or cooling rack, in a draft-free area, leaving 2 inches of space around all sides of the jars. Let cool for 12-24 hours.
14. After cooling time is complete, remove the rings and check the seals by depressing the center of the canning lid. If it pops back up, it is not sealed. Reprocess within 24 hours or refrigerate immediately and eat the contents within a few days. Store the sealed jars in a cool, dark place.

## **Processing Times**

**Steam canners and water bath canners both use the same processing times.**

Processing times will vary based upon the product that is being canned and the recipe that is used. Please refer to the USDA's website for approved canning guides and recipes, [nchfp.uga.edu](http://nchfp.uga.edu). A few USDA approved recipes have been attached to the end of this manual.

## TROUBLESHOOTING GUIDE

PROBLEM	SOLUTION
The indicator does not reach the green area for my zone.	<p><b>CHECK THE FOLLOWING:</b></p> <p>Have you followed the Temperature Indicator Testing Instructions on page 9 ? Is the water boiling, and has the water been boiling for longer than 40 minutes? Is the lid seated correctly on top of the pot? Are you looking at the correct Zone for your altitude?</p> <p>If you can answer yes to all of the above and the indicator is still not reaching the green area, please contact customer service at 1-866-257-4741.</p>
The lid is bouncing or rising during processing.	Burner temperature is too high. Gradually reduce the heat setting until the lid stops rising.
The water runs out of my pot before the processing time is reached.	Burner temperature is too high. Reduce heat. <b>DO NOT</b> boil the water rapidly during the entire processing time. A slow rolling boil is sufficient to maintain the temperature inside the pot. Be sure to refill the water to be even with the rack each time a batch is started.
Which “Zone” on the indicator should I use?	Make sure you know the altitude for your area before you start canning. <b><u>You can get this information by contacting your local Extension Office.</u></b> You can also visit <a href="http://nchfp.uga.edu">nchfp.uga.edu</a> for more information.
How do I find my local Extension office?	Each state has a Cooperative Extension that represents the USDA, to give proper canning and food safety instructions to the public. You can visit <a href="http://www.csrees.usda.gov/Extension/">http://www.csrees.usda.gov/Extension/</a> to find your local office.

### **Canning Jar and Lid Selection**

Regular and wide-mouth jars labeled for home canning are the only jars recommended for use with this canner. These types of canning jars come in several different sizes depending upon your needs and recipe requirements. For further information on jar and lid selections and for jar cleaning and sterilization, please refer to the USDA’s Complete Guide to Home Canning.

## Recipes

All of the following recipes have been taken from the USDA's Complete Guide to Home Canning.

### Spiced Apple Rings

12 lbs Firm Tart Apples (maximum diameter, 2-1/2 inches)

12 c. Sugar

6 c. Water

1-1/4 c. White Vinegar (5% Acidity) 3 tbsp Whole Cloves

3/4 c. Red Hot Cinnamon Candies –or- 8 Cinnamon Sticks

1 tsp Red Food Coloring (optional) **Yield:** About 8 to 9 pints

**Procedure:** Wash apples. To prevent discoloration, peel and slice one apple at a time. Immediately cut crosswise into 1/2-inch slices, remove core area with a melon baller, and immerse in ascorbic acid solution (1/2 tsp. ascorbic acid/1 gallon water). To make flavored syrup, combine sugar, water, vinegar, cloves, cinnamon candies, or cinnamon sticks and food coloring in a 6-qt saucepan. Stir, heat to boil, and simmer for 3 minutes. Drain apples, add to hot syrup, and cook for 5 minutes. Fill hot jars (preferably wide-mouth) with apple rings and hot flavored syrup, leaving 1/2-inch headspace. Remove air bubbles and adjust headspace if needed. Wipe rims of jars with a dampened clean paper towel. Adjust lids and process.

#### **Processing Times:**

Altitude	Half Pints	Pints
0-1,000 ft	10 min	10 min
1,000-6,000 ft	15 min	15 min
Above 6,000 ft	20 min	20 min

*\*p. 2-8 in USDA's Complete Guide to Home Canning*

## Grapefruit & Orange Sections

**Quantity:** An average of 15 pounds is needed per canner load of 7 quarts; an average of 13 pounds is needed per canner load of 9 pints—an average of about 2 pounds yields 1 quart.

**Quality:** Select firm, mature, sweet fruit of ideal quality for eating fresh. The flavor of orange sections is best if the sections are canned with equal parts of grapefruit. Grapefruit may be canned without oranges. Sections may be packed in your choice of water, citrus juice or syrup.

**Procedure:** Wash and peel fruit and remove white tissue to prevent a bitter taste. If you use syrup, prepare a very light, light, or medium syrup (see USDA's guide, p. 2-5, for syrup instructions) and bring to a boil. Fill hot jars with sections and water, juice or hot syrup, leaving 1/2-inch headspace. Remove air bubbles and adjust headspace if needed. Wipe rims of jars with a dampened clean paper towel. Adjust lids and process.

### **Processing Times:**

Altitude	Half Pints	Pints
0-1,000 ft	5 min	10 min
1,000-6,000 ft	10 min	15 min
Above 6,000 ft	15 min	20 min

*\*p. 2-15 in USDA's Complete Guide to Home Canning*

## **Tomatillo Green Salsa**

5 c. Tomatillos, chopped (or green tomatoes may be used) 1-1/2 c. Long Green Chilies, seeded and chopped

1/2 c. Jalapeño Peppers seeded and finely chopped

4 c. Onions, chopped

1 c. Bottled Lemon Juice

6 Cloves Garlic, finely chopped

1 tbsp Ground Cumin (optional)

3 tbsp Oregano Leaves (optional)

1 tbsp Salt

1 tsp Black Pepper

**Yield:** About 5 pints

**Procedure: Caution! Wear plastic or rubber gloves and do not touch your face while handling or cutting hot peppers. If you do not wear gloves, wash hands thoroughly with soap and water before touching your face or eyes.** Combine all ingredients in a large saucepan and stir frequently over high heat until mixture begins to boil, then reduce heat and simmer for 20 minutes, stirring occasionally. Ladle hot salsa into hot pint jars, leaving 1/2-inch headspace. Remove air bubbles and adjust headspace if needed. Wipe rims of jars with a dampened clean paper towel. Adjust lids and process.

**Processing Times:**

Altitude	Pints
0-1,000 ft	15 min
1,000-6,000 ft	20 min
Above 6,000 ft	25 min

*\*p. 3-22 in USDA's Complete Guide to Home Canning*

## **Product Warranty**

Register your warranty online at:  
**VKPbrands.com/Warranty**

Model VKP1054 - FruitSaver Steam Canner: 5 years

We are confident in the quality of our products and back each one with a limited warranty for the length of time specified above. Should you experience any problems with your product, please contact our Customer Service Department.

All warranty claims must be accompanied by a proof of purchase and are only valid if the appliance has been operated within the U.S. or Canada and used for its intended purposes. These products are for household use only.

### **Items Not Covered:**

- Return shipping costs or returned items lost in transit.
- Damages to the product due to accident, misuse, abuse, negligence, or if the appliance has been altered in any way.
- Products used outside of the United States or Canada.

# **VKP™**

**B R A N D S**

1804 Sandhill Rd

Orem UT, 84058

Phone: **866-257-4741**

**VKPbrands.com**