



**Roots &  
Branches™**  
Preserving The Tradition

---

# DELUXE GRAIN MILL MOTOR

## Instruction Manual

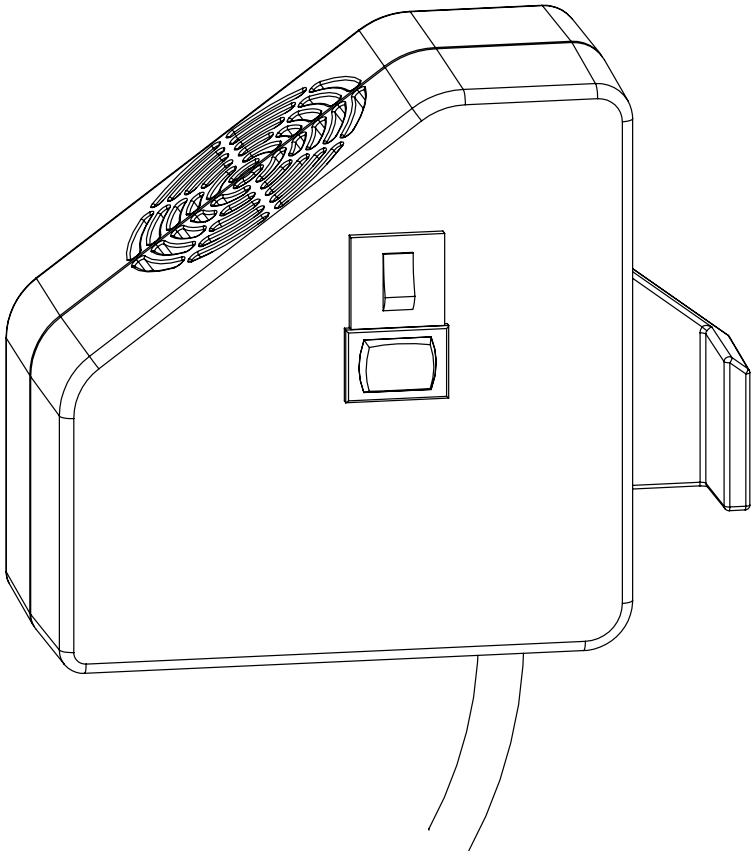

## Table of Contents

Features.....	3
Important Safety Instructions.....	4
Grounding Instructions .....	5
Circuit Breaker Instructions .....	6
Motor Use Instructions.....	7
Removal Steps .....	8
Notes.....	11
Product Warranty.....	12

\*For the most up-to-date manual, or for more information regarding this product, visit our website: **VKPbrands.com**

# Deluxe Grain Mill Motor

## VKP1024-M

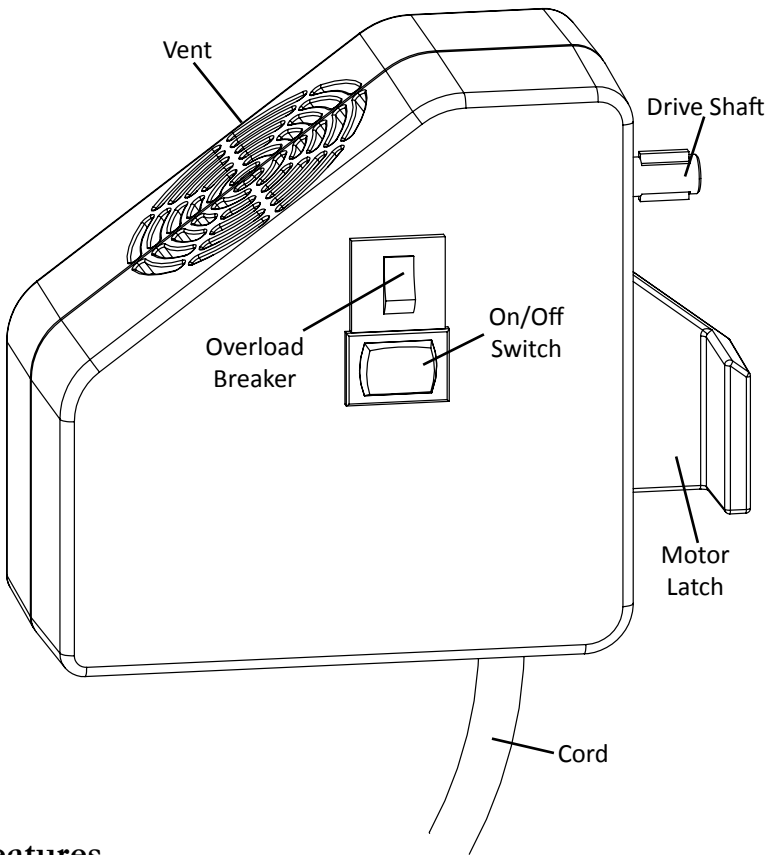

### Features

- Installs quickly and is easy to use.
- Energy efficient and durable.
- High torque power combined with all metal gears provide years of reliable service.
- Very low power consumption keeps your power bill low and allows for worry free use with backup emergency power such as generators or a battery powered electrical inverter.
- Motor specifications: 120 VAC, 60 HZ, 90 WATTS, 50 RPM

## **IMPORTANT SAFETY INSTRUCTIONS**

**WARNING! - Failure to follow these safety instructions correctly will lead to a risk of fire, electric shock or personal injury.**

### **SAVE THESE INSTRUCTIONS**

When using electric appliances, basic precautions should always be followed, including the following:

- **Read and follow all instructions before operating the motor.**
- Connect motor to a properly grounded outlet only (See ‘Grounding Instructions’ on p. 3).
- Do not use electrical outlet adapters with this appliance.
- Do not operate if the cord or plug is damaged, or after the appliance malfunctions, or is dropped or damaged in any way. Return the appliance to the manufacturer for examination, repair, or electrical or mechanical adjustment.
- Do not disassemble. The motor must be serviced by qualified technicians only.
- To disconnect the motor, turn all controls to the off (“O”) position, then remove the plug from the outlet.
- Do not unplug by pulling on the cord. To unplug, grasp the plug, not the cord.
- Do not leave the motor plugged in when not in use and before servicing or cleaning.
- Keep the motor unplugged and make sure the switch is in the off (“O”) position when installing or uninstalling from the grain mill.
- Never turn on the motor with nothing in the grain mill.
- To reduce the risk of electric shock, do not immerse the motor in water or other liquid. Do not place or store the motor where it can fall or be pulled into a tub or sink.
- Children should only use the Grain Mill under adult supervision.
- Do not contact any moving parts.
- NEVER put hands or foreign objects in the grain mill hopper.

- Never use the grain mill without the hopper in place.
- Do not cover the motor ventilation holes.
- Make sure the motor is attached to the grain mill properly before operating (See ‘Motor Use Instructions’ on p. 5).
- This appliance is for household use only.

## **Grounding Instructions**

(See diagrams below)

**THIS APPLIANCE MUST BE GROUNDED.** In the event of malfunction or breakdown, grounding provides a path of least resistance for electric current to reduce the risk of electric shock. This appliance is equipped with a cord having an equipment-grounding conductor and a grounding plug. The plug must be plugged into an appropriate outlet that is properly installed and grounded in accordance with all local codes and ordinances.

**DANGER** – Improper connection of the equipment-grounding conductor can result in a risk of electric shock. The conductor with insulation having an outer surface that is green with or without yellow stripes is the equipment-grounding conductor. If repair or replacement of the cord or plug is necessary, do not connect the equipment-grounding conductor to a live terminal. Check with a qualified electrician or serviceman if the grounding instructions are not completely understood, or if in doubt as to whether the appliance is properly grounded. Do not modify the plug provided with the appliance – if it will not fit the outlet, have a proper outlet installed by a qualified electrician.

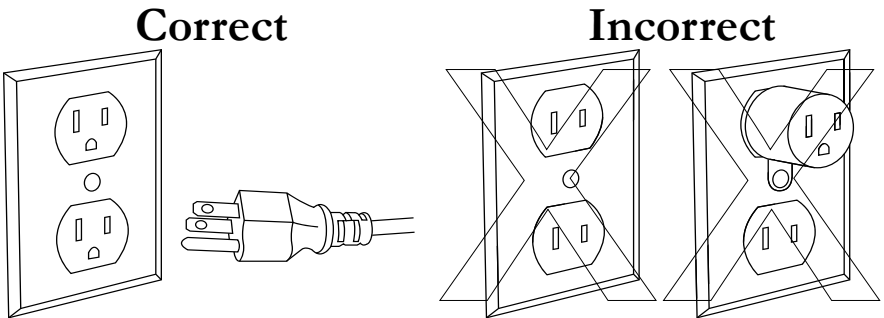

## Circuit Breaker Instructions

The motor includes a resettable overload breaker to prevent risk of personal injury or grain mill damage.

**Instructions for resetting overload breaker:** Turn the switch to the off (“O”) position and unplug the motor from the outlet. Remove the motor from the grain mill. Wait 10 minutes for the motor to cool, then manually reset the breaker by pressing in on the top of the breaker until it locks.

**Important:** Before reinstalling the motor, check the grain mill operation by installing the handle and manually operating the grain mill to make sure the milling cone isn’t jammed or overly hard to turn. If the grain mill is jammed then the adjustment knob, milling cone and shaft must be removed to inspect and clear any obstructions.

**Caution:** If the breaker trips immediately after plugging in or turning on the motor, do not bypass the breaker and do not use the motor. Contact VKP Brands Customer Service at 866-257-4741.

### Power Switch

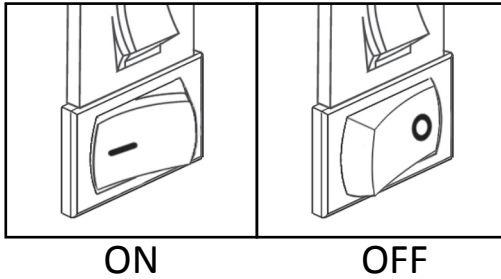

ON

OFF

### Overload Breaker

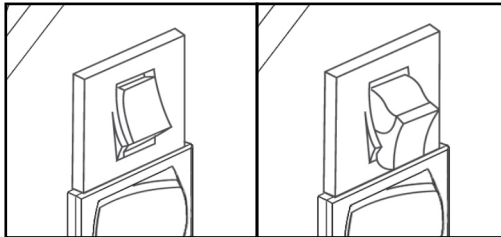

Breaker in normal  
operating position

Breaker that has  
been tripped

Motor Specifications: 120 VAC, 60 HZ, 90 WATTS, 50 RPM

## Motor Use Instructions

Make sure you have read the Important Safety Instructions on p. 11 before installing the motor.

### Installation Steps:

1. Remove the motor from the packaging and make sure the power switch is in the off (“O”) position (see diagram on p. 4) and the motor is unplugged.
2. Use the crank handle to position the grain mill shaft so the motor shaft key is aligned with the notches (see diagram at right).
3. Once the shaft is positioned correctly, insert the motor shaft into the grain mill shaft by pushing forward on the motor.
4. Now that the motor has been inserted, twist the motor counter-clockwise to lock it into place (see diagrams below).

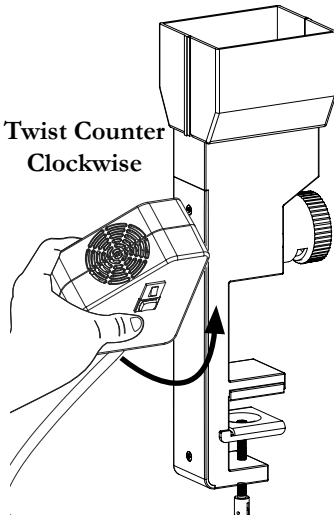
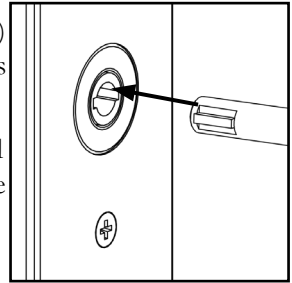

**Twist Counter  
Clockwise**

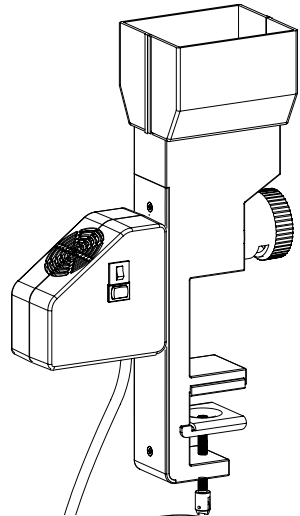

5. You will know the motor has been installed correctly when the motor latch is secure around the grain mill body (see diagram at right).

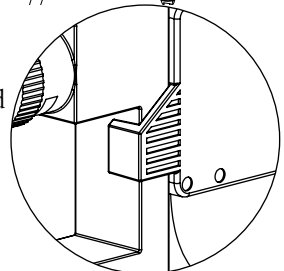

6. Make sure the power switch is still in the off (“O”) position and plug the motor cord into a correct power source (see diagram on p. 3).
7. **WARNING! - Do not turn on the motor at this point! You will damage your grain mill by running it without grain.**
8. Now that the motor is connected properly and plugged in, you can add your grain to the hopper.
9. You may now turn the power switch to the on (“I”) position. **Never use any tools in the hopper. Keep hands, hair, clothing and any other foreign objects, away from the hopper opening at all times.**

## Removal Steps

1. To remove the motor, make sure the power switch is in the off (“O”) position and the cord is unplugged.
2. Firmly grasp the motor and twist in a clockwise direction to release the motor latch from the body of the grain mill. (See diagrams below).

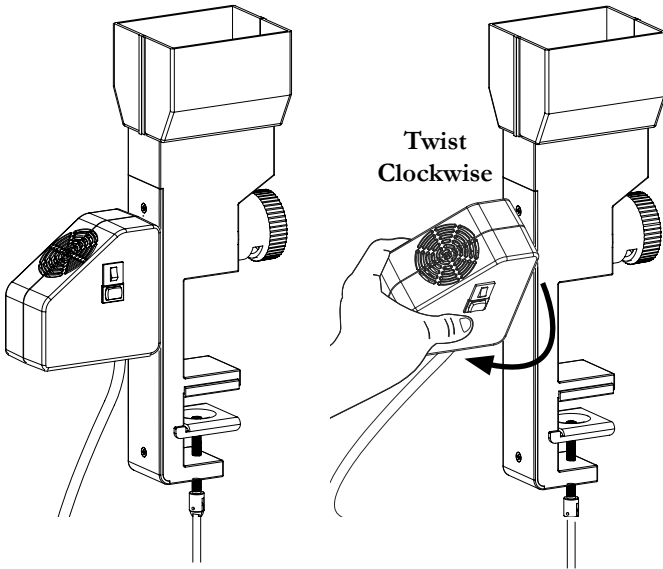



3. The motor may be tight or hard to remove. If so, rock it up and down gently as you pull straight back. (See diagram below).

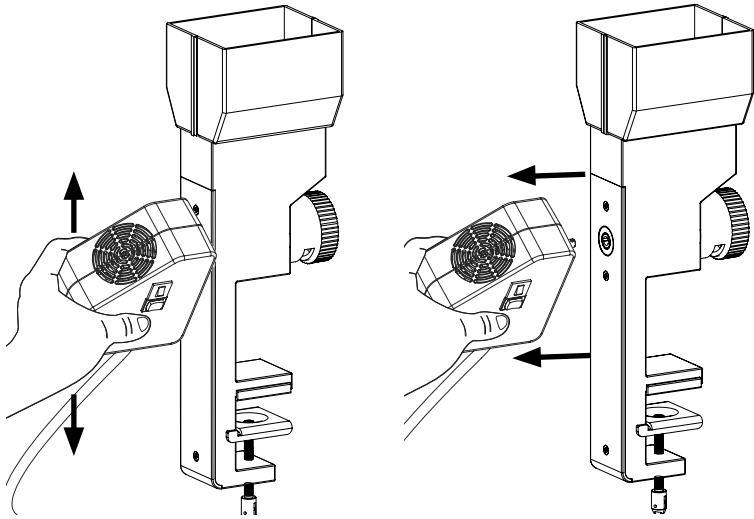

4. If needed, you can clean the motor by using a damp cloth to wipe away any dust or residue on the outside surfaces. Dry immediately. **Never immerse in water or disassemble to clean.**
5. To store, place the motor back in its original box and packaging and keep it in a cool, dry place, away from moisture and extreme temperatures.

## MOTOR TROUBLESHOOTING GUIDE

PROBLEM	SOLUTION
I cannot attach the motor.	Review p. 5 on how to attach the motor, including how to correctly align the motor shaft with the grain mill shaft.
I cannot remove the motor.	Sometimes the motor shaft can get stuck or be difficult to remove. Read <u>all</u> the Removal Steps on p. 6.
The motor is working but no grain is going through the mill.	Sometimes grain can get stuck and will not flow into the grinding chamber. Gently tap the side of the grain mill, just below the hopper, using the side of your fist or heel of your hand. This will loosen the grains and help them flow into the grinding chamber.
Grain is going through, but the grain mill is producing very little or no flour.	Make certain, after you tighten the adjustment knob, you turn it back at least <u>1/4</u> turn. An overly-tightened adjustment knob can damage the milling cone, especially while using the motor.
The motor does not turn on.	Review the instructions and diagram on p. 4 about the Power Switch and the Overload Breaker.
The motor does not turn on and the overload switch is not tripped.	Make sure the cord is plugged into a <u>live</u> power outlet. Review the diagram on p. 4 about the Power Switch. Make sure the switch on your motor matches the diagram for the on, (“I”) position.

## Notes

## **Product Warranty**

Register your warranty online at:  
**VKPbrands.com/Warranty**

Model VKP1024-M2 - Motor Warranty: 5 years

We are confident in the quality of our products and back each one with a limited warranty for the length of time specified above. Should you experience any problems with your product, please contact our Customer Service Department.

All warranty claims must be accompanied by a proof of purchase and are only valid if the appliance has been operated within the U.S. or Canada and used for its intended purposes. These products are for household use only.

### **Items Not Covered:**

- Return shipping costs or returned items lost in transit.
- Damages to the product due to accident, misuse, abuse, negligence, or if the appliance has been altered in any way.
- Products used outside of the United States or Canada.

# **VKP™**

**B R A N D S**

1804 Sandhill Rd

Orem UT, 84058

Phone: **866-257-4741**

**VKPbrands.com**